



*Great sound  
from Barcelona  
since 1972*

[www.amateaudio.com](http://www.amateaudio.com)

## User's manual

N12WP

N18WP

N218WP

NÍTID  
*#purelynitid*

May 2018

Amate Audio S.L.

EXPORT & CUSTOMER SERVICE  
Perpinyà, 25 · Polígon Industrial Nord  
08226 Terrassa · Barcelona – SPAIN  
T. +34 93 735 65 65  
[export@amateaudio.com](mailto:export@amateaudio.com)

R&D, FACTORY AND MANAGEMENT  
Violinista Vellsolà, 18  
08222 Terrassa · Barcelona – SPAIN  
T. +34 93 736 23 90  
[info@amateaudio.com](mailto:info@amateaudio.com)

## **Safety Instructions**

1. All safety instructions must be read before using this device.
2. Keep and follow these instructions
3. Heed all warnings
4. The exclamation mark in the triangle indicates internal components which if replaced can affect safety.
5. The lightning symbol within the triangle indicates the presence of dangerous uninsulated voltages.
6. Only clean the device with a dry cloth.
7. Do not block any ventilation openings. Install in accordance with the manufacturer's instructions.
8. Do not install the device near heat sources such as radiators, heaters or other heat-emitting elements.
9. Protect the power cord from being walked on or pinched, particularly at plugs, convenience receptacles, and the point where they exit from the apparatus
10. The equipment must be repaired by qualified technical service personnel when:
  - A. The mains supply cable is damaged, or
  - B. Any object or liquid has damaged the device; or
  - C. The equipment does not function normally or correctly; or
  - D. The equipment has been exposed to the rain; or
  - E. The chassis is damaged
11. Disconnect the device in the case of electric storms or during long periods of disuse.
12. **WARNING** – To reduce the risk of fire or electric shock, do not expose this device to rain or moisture
13. The equipment shall not be exposed to dripping or splashing and no objects filled with liquids, such as vases, shall be placed on the device.
14. For hanging and installation, use manufacturer recommended accessories only.

## 1. INTRODUCTION

### 1.1. General

Amate Audio would like to thank you for your confidence in our NITID Series. We suggest you to carefully read the following instructions in order to obtain the best results in performance.

### 1.2. Features and presentation

#### N12WP

- Passive subwoofer
- NL4MPR Speakon input & parallel output
- 800 W program power
- Sensitivity 1 W / 1 m: 96 dB
- 12" woofer with 3" voice coil
- Nominal impedance 8

#### N18WP

- Passive subwoofer
- NL4MPR Speakon input & parallel output
- 2400 W program power
- Sensitivity 1 W / 1 m: 98 dB
- 18" woofer with 4" voice coil
- Nominal impedance 8

#### N218W

- Passive subwoofer
- NL4MPR Speakon input
- 4800 W program power
- Sensitivity 1 W / 1 m: 102 dB
- 2 x 18" woofers with 4" voice coil
- Nominal impedance 4

## 2. CONNECTIONS

### 2.1. Connection description (N18WP)

**A) SPEAKON:** The N18WP uses two NL4MPR Speakon terminals and is duly prepared for a perfect connection in a parallel system. Terminal Pins +1/-1 must be always used, disregarding the +2/-2 which are not internally connected. Respect always the polarity +/-.

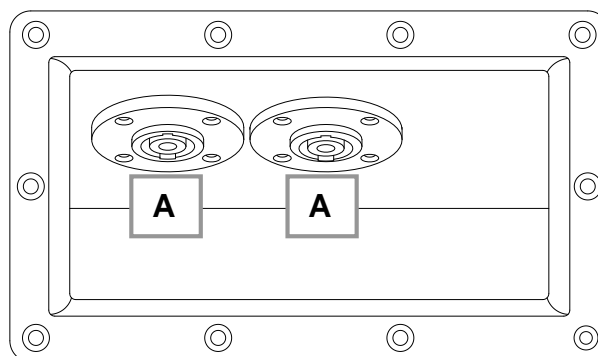
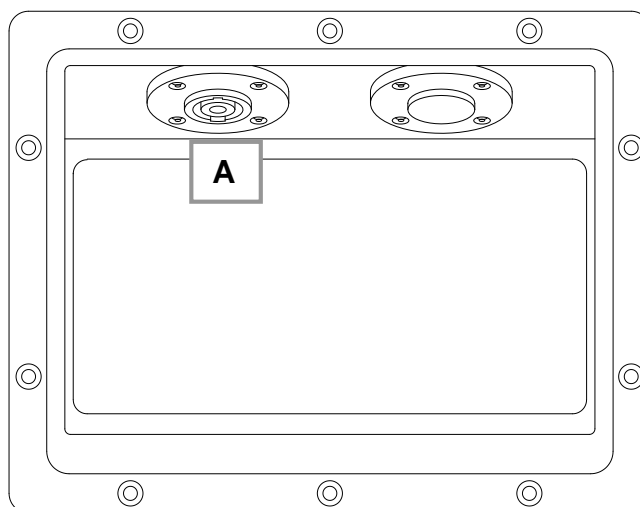

Fig. 1. N18WP connectors

## 2.2. Connection description (N218WP)

**A) SPEAKON:** The N218WP uses one NL4MPR Speakon terminal. Terminal Pins +1/-1 must be always used, disregarding the +2/-2 which are not internally connected. Respect always the polarity +/-.



**Fig. 2.** N218WP connectors

## 2.3. Connection description (N12WP)

**A) SPEAKON:** The N12WP uses two NL4MPR Speakon terminals and is duly prepared for a perfect connection in a parallel system. Terminal Pins +1/-1 must be always used, disregarding the +2/-2 which are not internally connected. Respect always the polarity +/-.

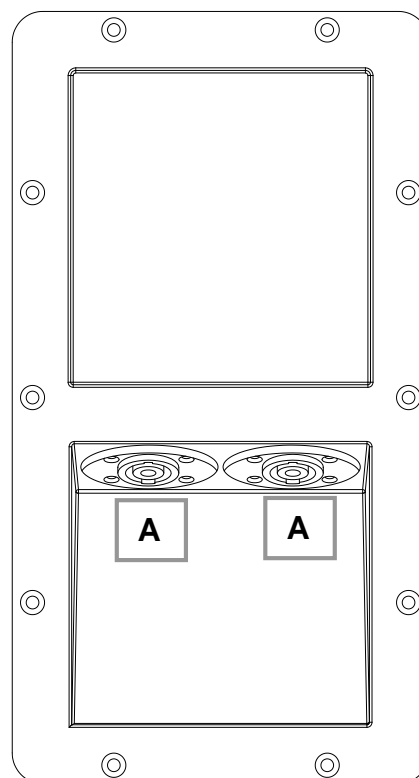

**Fig. 3.** N12WP connectors



It is strongly recommended to use a two-conductor high quality wire, non-shielded and two-coloured. We recommend using a minimum section of 4 mm<sup>2</sup> for each conductor. Avoid long wire distances as they induce to important power and quality losses.

**2.4. Recommended set-up for N12WP passive subwoofer**

<b>Model</b>	DSP206/608
--------------	------------

<b>Model</b>	N12WP
<b>Impedance</b>	8

<b>Model</b>	N12WP
<b>Impedance</b>	8

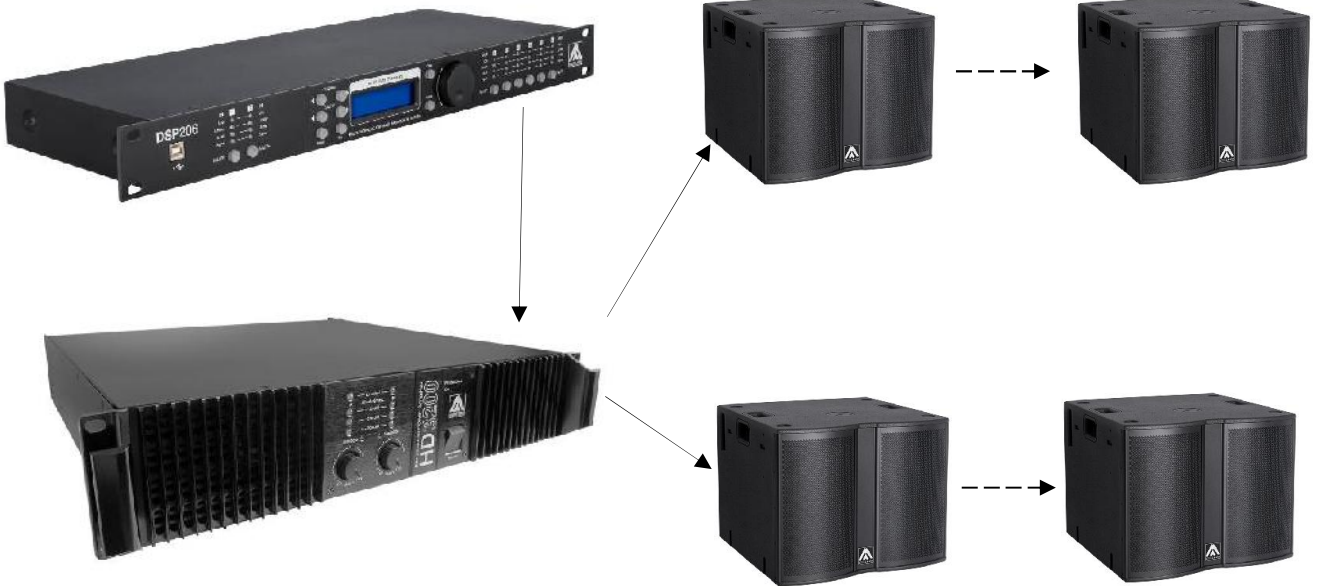

<b>Model</b>	HD3200	
<b>Mode</b>	Stereo	Stereo
<b>Impedance</b>	8	4
<b>Program power</b>	1000W	1750W

<b>Model</b>	N12WP
<b>Impedance</b>	8

<b>Model</b>	N12WP
<b>Impedance</b>	8

One unit of HD3200 (in stereo mode) can feed up to four units of N12WP.

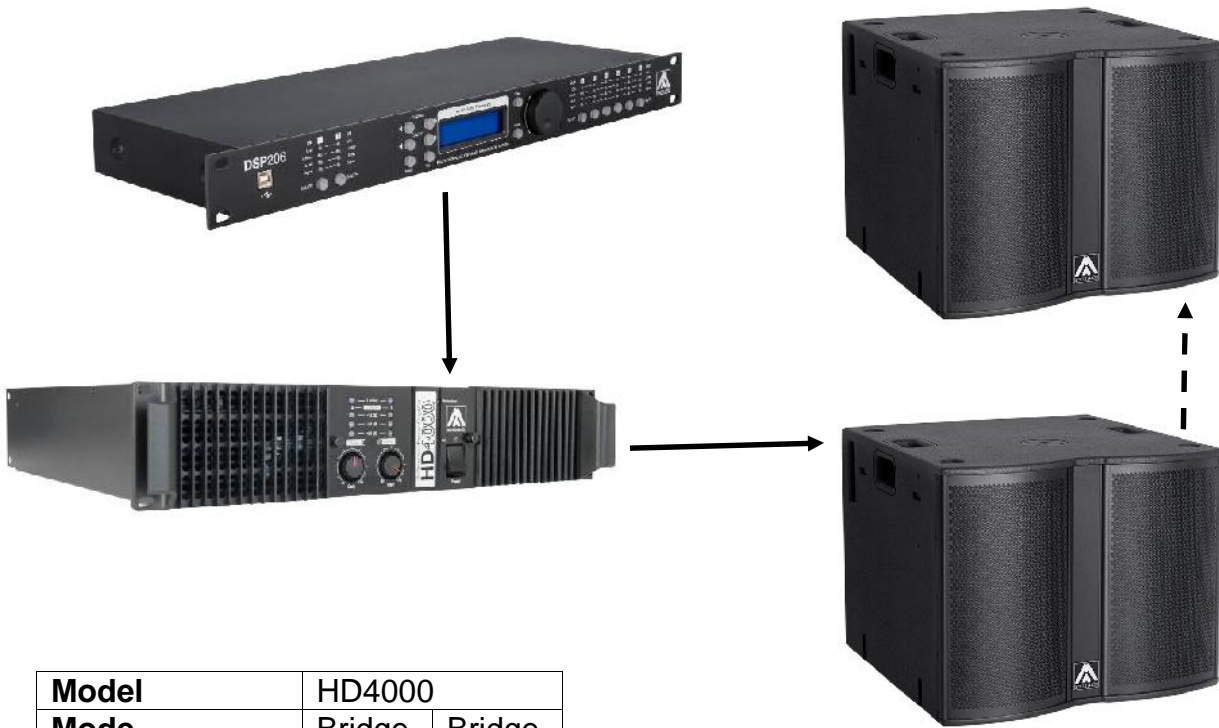

**Fig. 4.** N12WP configuration

**2.5. Recommended set-up for N18WP passive subwoofer**

<b>Model</b>	DSP206/608
--------------	------------

<b>Model</b>	N18WP
<b>Impedance</b>	8



<b>Model</b>	HD4000	
<b>Mode</b>	Bridge	Bridge
<b>Impedance</b>	4	8
<b>Program power</b>	4000W	2400W

<b>Model</b>	N18WP
<b>Impedance</b>	8

One unit of HD4000 (in bridge mode) can feed up to two units of N18WP

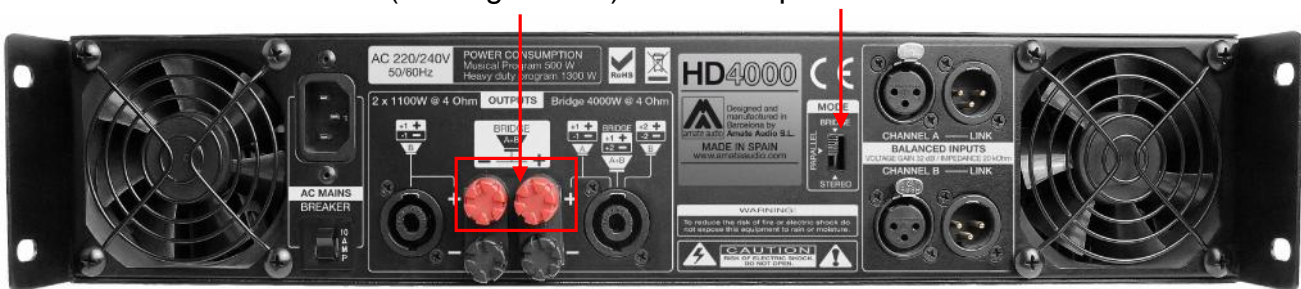

**Fig. 5.** N18WP configuration

### 2.6. Recommended set-up for N218WP passive subwoofer

<b>Model</b>	DSP206/608
--------------	------------

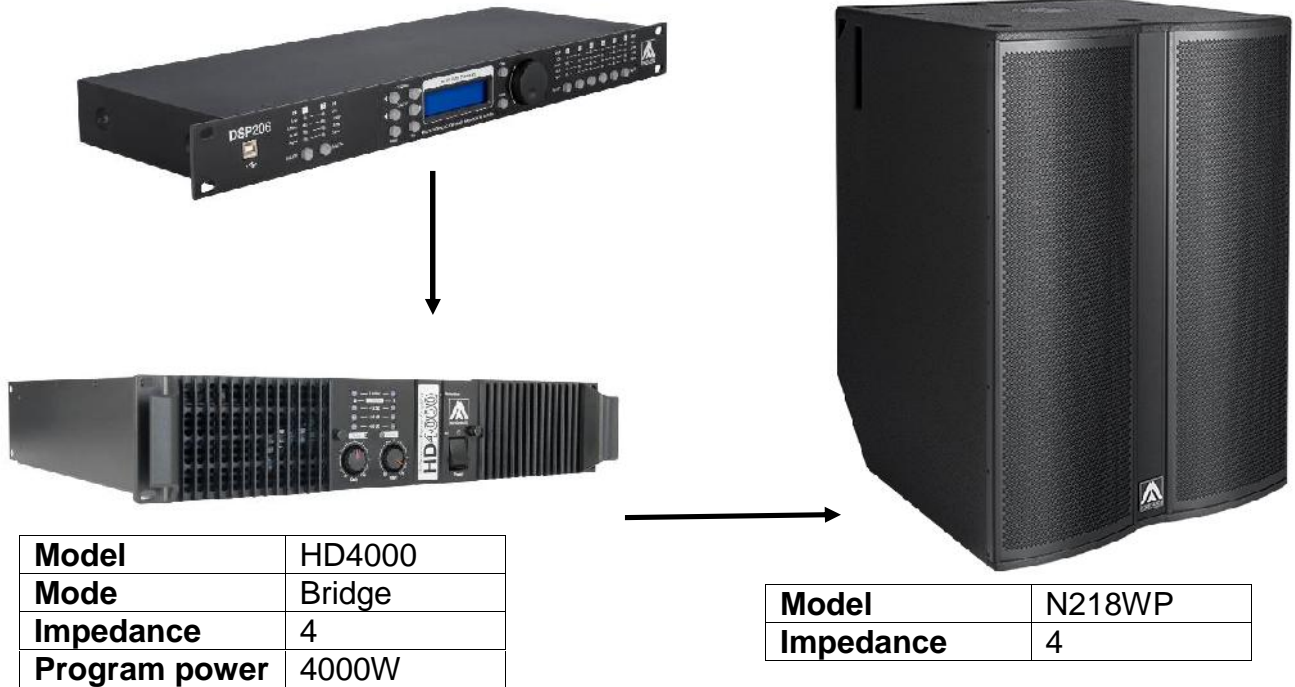

One unit of N218WP needs one unit of HD4000 (in bridge mode)

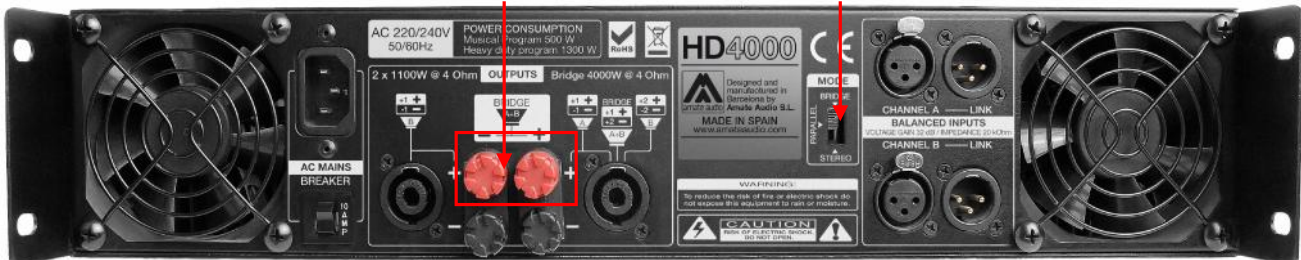

Fig. 6. N218WP configuration

### 2.7. Recommended presets for N12WP, N18WP, N218WP

The N12WP, N18WP and N218WP can be used with an external DSP206/608 (digital signal processor).

**ATTENTION:** When the N12WP, N18WP or N218WP are used in conjunction with the Full-range NITID systems in SPEECH or XOVER presets, the N12WP, N18WP and N218WP must operate in positive polarity.

When the N12WP, N18WP or N218WP are used in conjunction with the Full-range NITID systems in FLAT, NEARFIELD, LONGTHROW, SMOOTH, MONITOR presets, the N12WP, N18WP and N218WP must operate in negative polarity.

### LPF80

80 Hz low pass filter

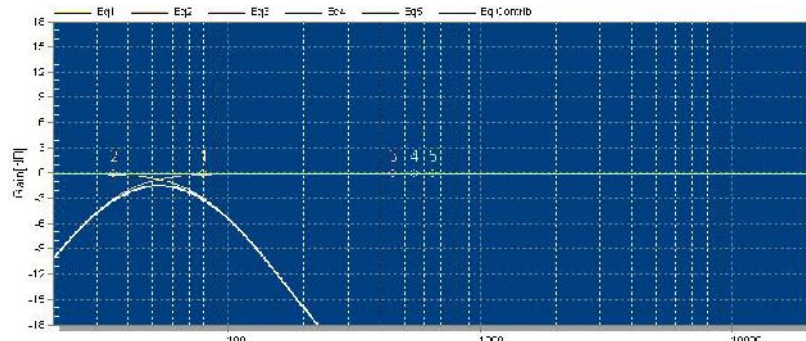

### LPF80+3

80 Hz low pass filter  
3) +3dB boost at 50Hz (N12WP,N18WP)  
3) +3dB boost at 44Hz (N218WP)

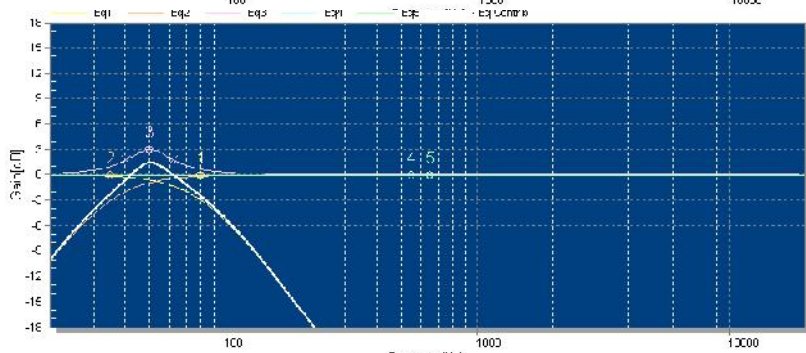

### LPF90

90 Hz low pass filter

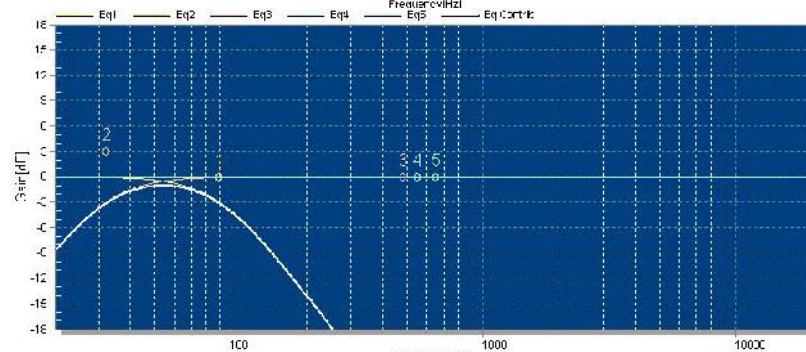

### LPF90+3

90 Hz low pass filter  
a 90Hz  
3) +3dB boost at 50Hz (N12WP,N18WP)  
3) +3dB boost at 44Hz (N218WP)

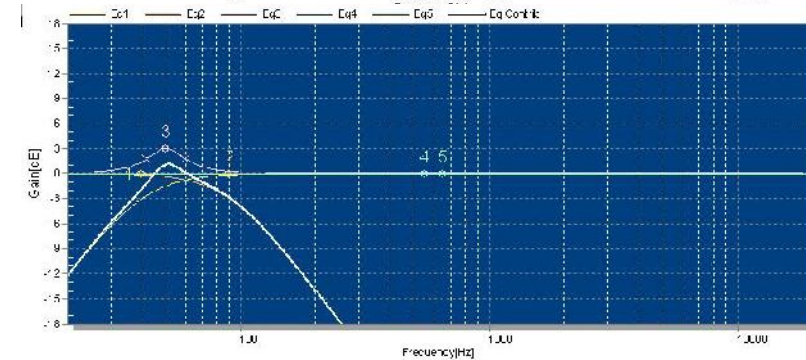

### LPF100

100 Hz low pass filter

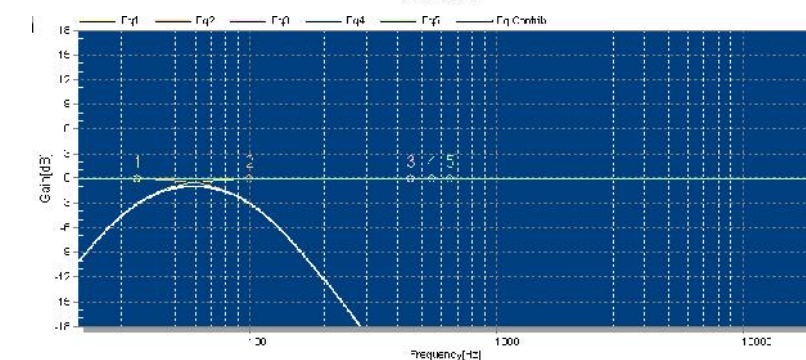



**LPF100+3**

100 Hz low pass filter  
3) +3dB boost  
at 50Hz (N12WP,N18WP)  
3) +3dB boost  
at 44Hz (N218WP)

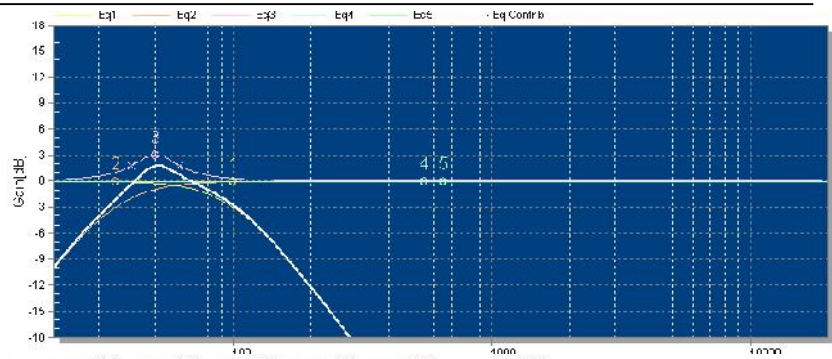

**LPF110**

110 Hz low pass filter

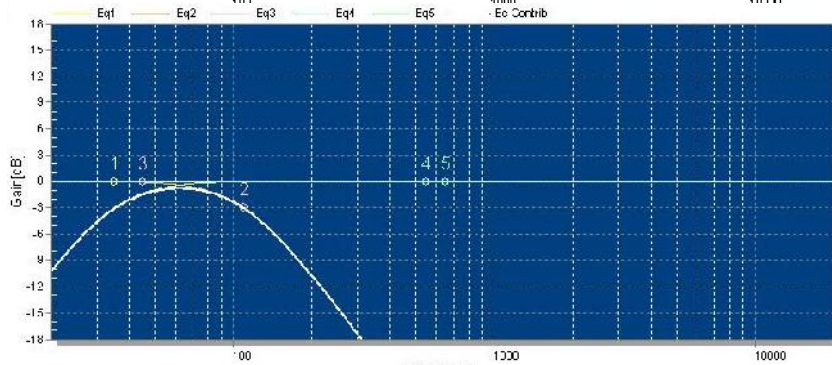

**LPF110+3**

110 Hz low pass filter  
3) +3dB boost  
at 50Hz (N12WP,N18WP)  
3) +3dB boost  
at 44Hz (N218WP)

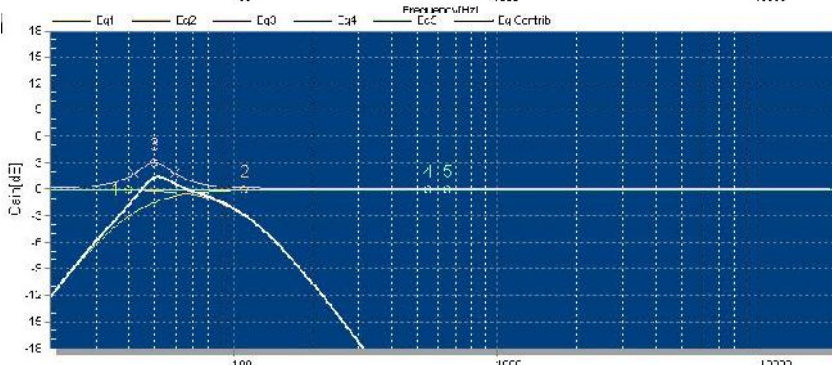

**LPF120**  
**(only for N12WP, N18WP)**

120 Hz low pass filter

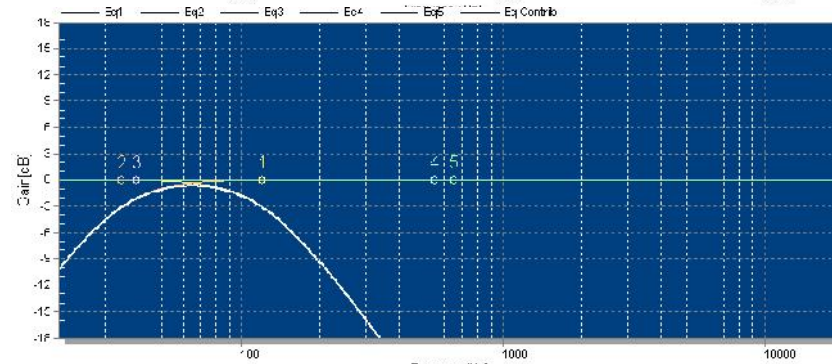

**LPF120+3**  
**(only for N12WP, N18WP)**

120Hz low pass filter  
with +3dB boost  
at 50Hz

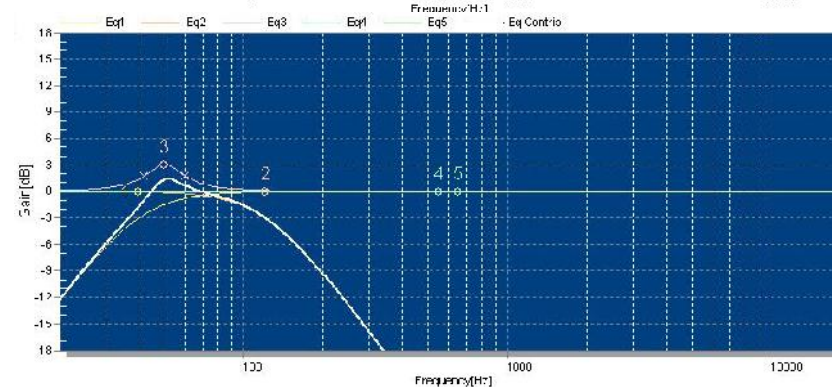

**CARD80/90/100/110/120\***

(\*120 only for N18WP)

Cardioid polar pattern, with processing, delay and inverse polarity

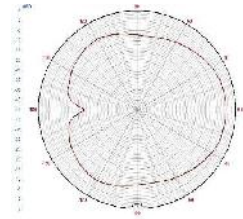

**Fig. 7.** Recommended PRESETS for N12WP, N18WP and N218WP

**3. MOUNTING AND PLACEMENT**

For a proper installation of the acoustic cabinet systems, it is strongly recommended to carefully read the following advices.

**3.1. N12WP, N18WP and N218WP with full-range systems**

The N12WP and N18WP incorporate a M20 base-plate on its upper side for the attachment of a standard 35mm diameter bar.

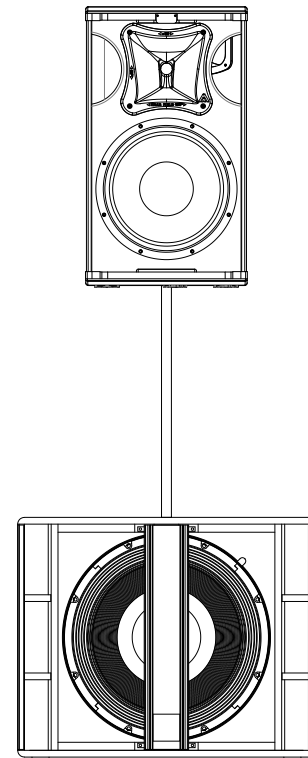
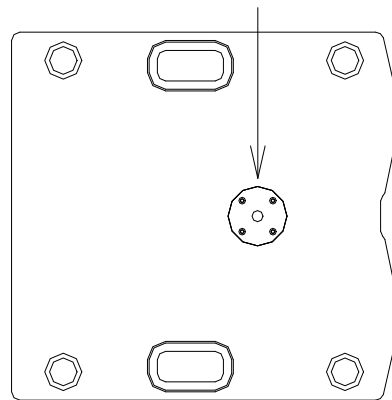

**Fig. 8.** N18WP socket

The N218WP incorporates a M10 base-plate on their upper side for the attachment of a stacking frame (FR-X208)

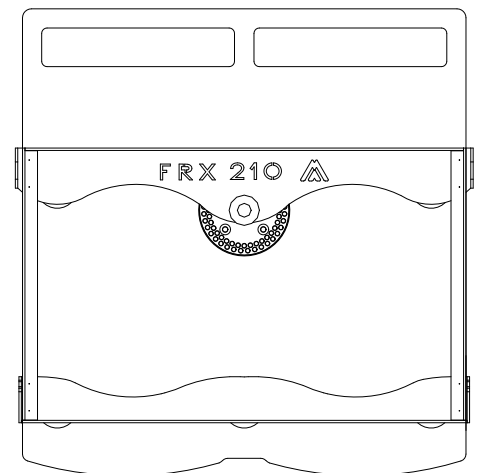
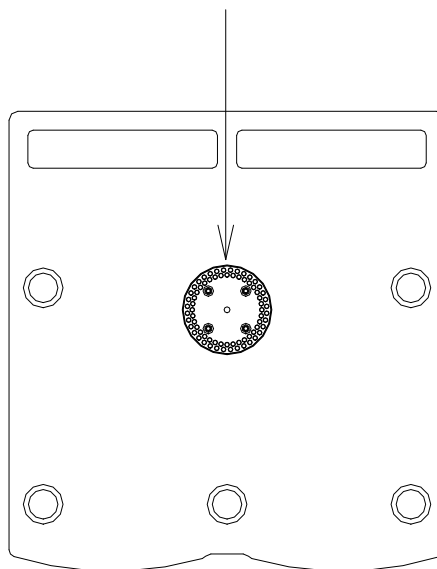

**Fig. 9.** N218WP socket

The PA-2010 is an optional accessory to adapt an M20 thread distance rod bar to the N218WP subwoofers.

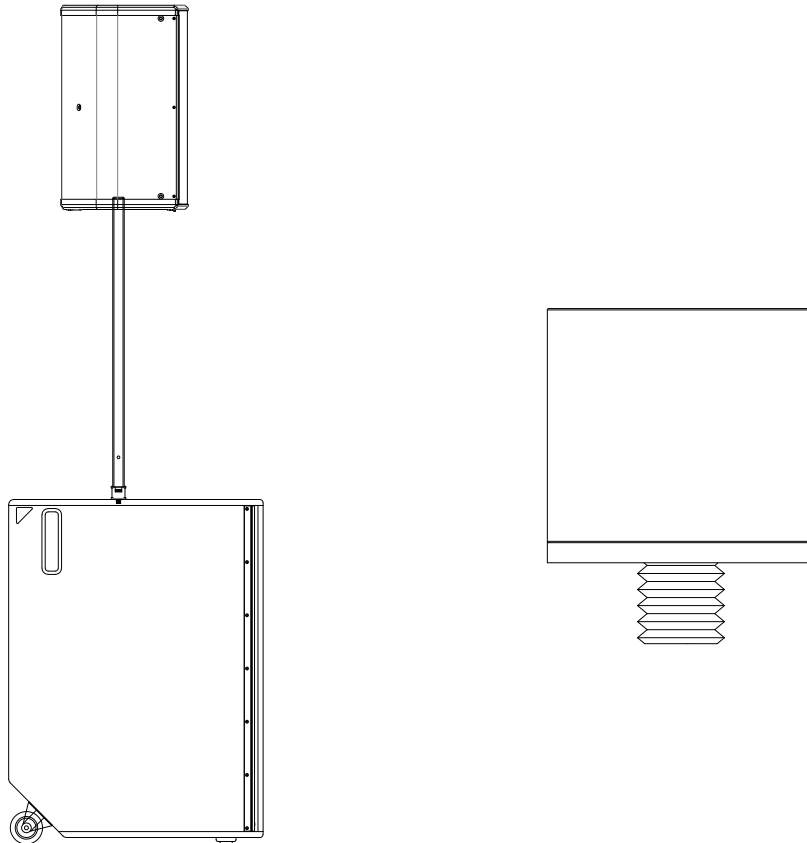

**Fig. 10.** PA-2010

### 3.2. N18WP + N208 Flying

Flying a NITID system is easy, fast and secure. To perform any operations related to flying the systems, read the present document, and act on the warnings and advice given.

Only experienced installers with adequate knowledge of the system and local safety regulations should fly speaker cabinets.

It is the user's responsibility to ensure that the systems to be flown and the flying accessories (such as chains, eyebolts, lock pins...) comply with state and local regulations. They should be regularly inspected and replaced if in doubt.

When flying enclosures from ceiling support structures, extreme care should be taken to assure the load bearing capabilities of the structures. **Do not fly systems from unsafe structures.**

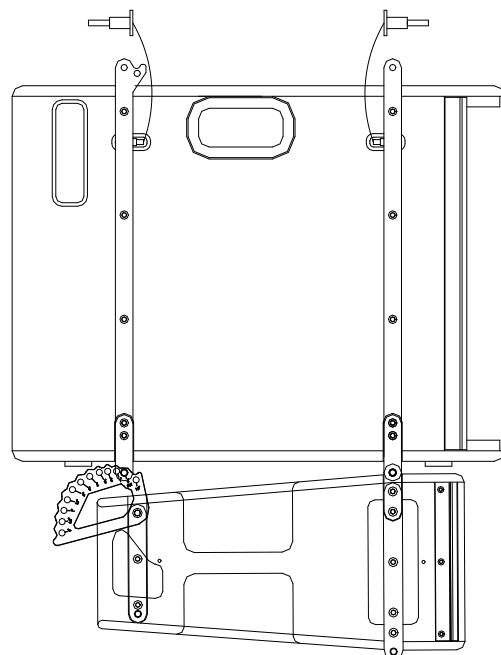

All flying accessories that are not supplied by Amate Audio are the user's responsibility. Use at your own risk.

It is useful to fly low frequency reinforcement units on the top of the system, as they are the heaviest enclosures. Place the subwoofers and cabinets as has been explained in KR-18T user's manual.

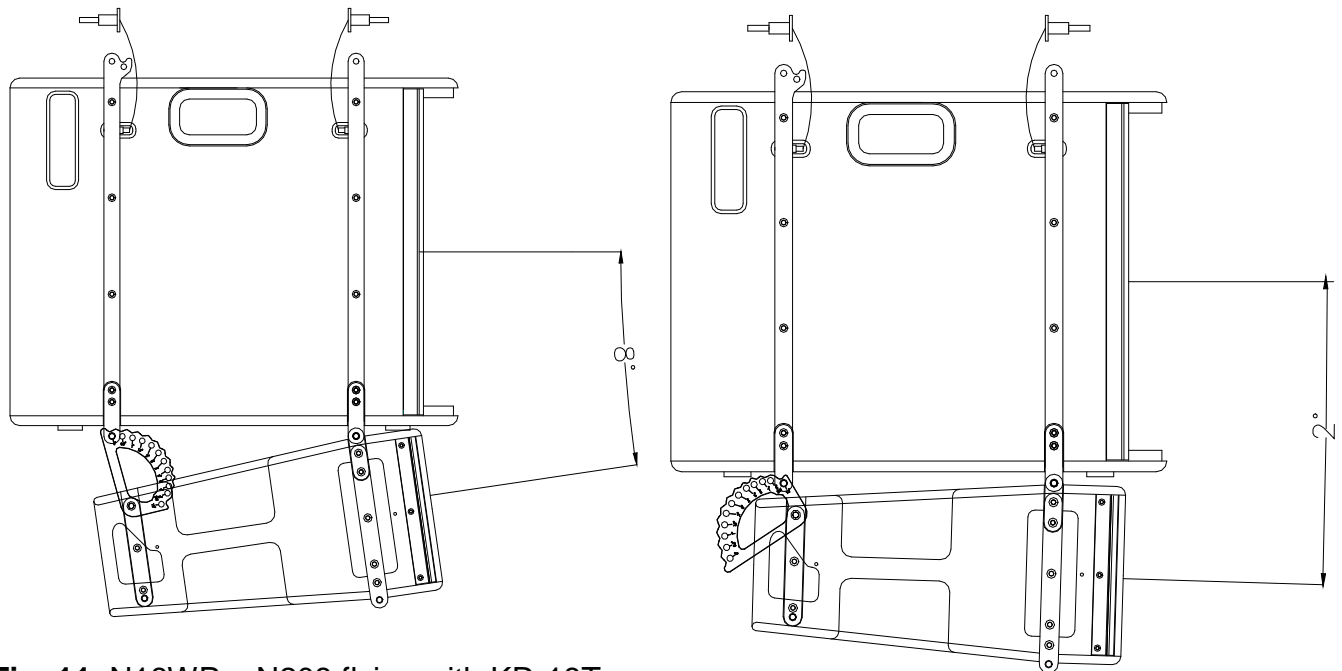

**Fig. 11.** N18WP + N208 flying with KR-18T accessory

#### 4. CARDIOID SUBWOOFERS

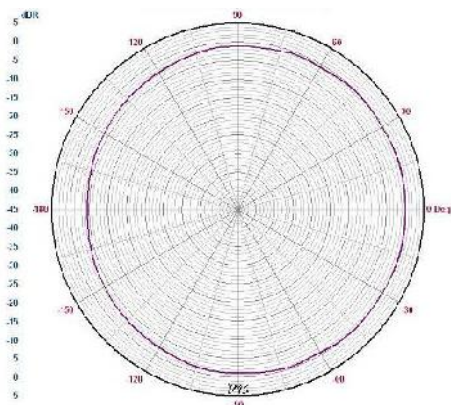

N12WP, N18WP and N218WP enable the combination of three or multiple of three subwoofer cabinets in an array to provide exceptional directivity at low frequencies. To get the correct set-up parameters, please contact [export@amateaudio.com](mailto:export@amateaudio.com). High directivity at low frequencies has two main effects on the sound field: firstly, the low frequency level behind the subwoofer cabinets is greatly reduced; secondly, in closed venues the diffuse sound field at low frequencies is reduced so the low frequency reproduction is much more precise.

**Fig. 12.** Traditional polar pattern of a subwoofer at 40Hz

The typical operating range of a traditional subwoofer tends to be like a monopole, i.e. tends to radiate with the same energy in all directions. This behaviour implies that the control of radiation at low frequencies is very difficult because the wavelengths are very large compared to the size of the source (8.5 m at 40Hz).

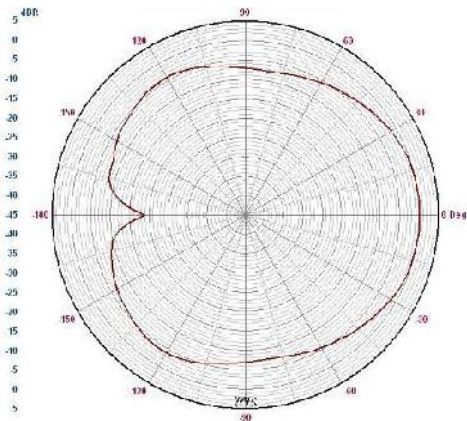

**Fig. 13.** Cardioid pattern

To increase the directivity at low frequencies we must transform the omnidirectional performance into a cardioid performance. This can only be achieved by various sources, arranged in a certain position, to which we apply a specific phase, filtering and delay. That is, we need to reproduce two signals with the same frequency and similar amplitude which will have a difference in phase of approximately  $180^\circ$  at a certain point of the sound field. If the phases and delays are well calculated the result is a system in which we cancel the energy of the back and not the one of the front.

#### 4.1. The CARDIOID presets

N12WP, N18WP and N218WP can generate an uncompromised cardioid behaviour when used in conjunction with an external Amate Audio DSP206/608 and their correct set-up parameters.

In its minimum and standard configuration a Cardioid setup consists of a stack of three subwoofer cabinets (for N12WP and N18WP) and of a horizontal line of three subwoofer cabinets (for N218WP).

Only one subwoofer is needed to compensate for the energy of the other two radiating to the front. Then, the cabinet facing to the back (to the stage) should be located in the centre of the column.

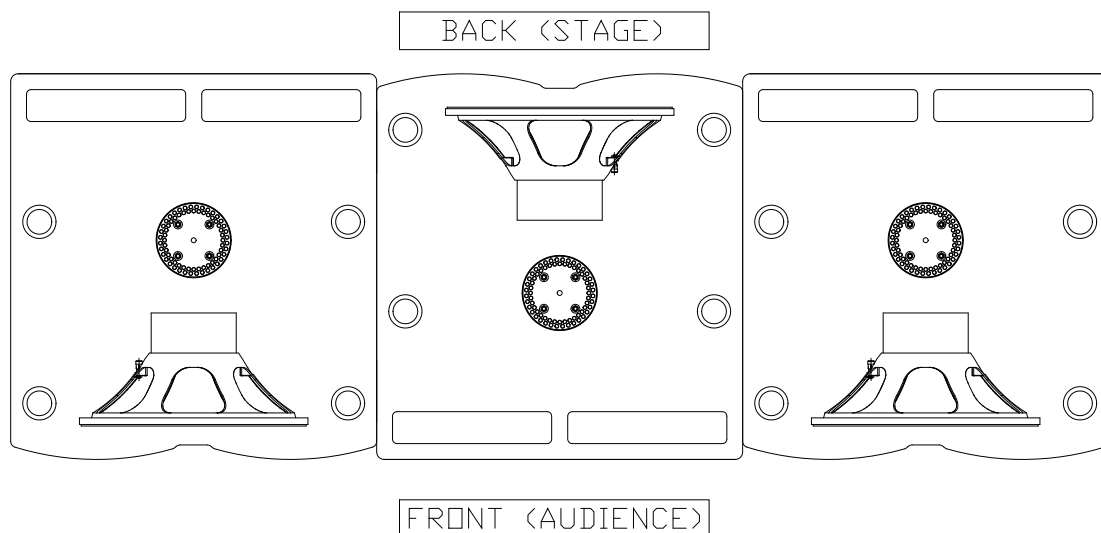

**Fig. 14.** Cardioid configuration for N218WP subwoofer

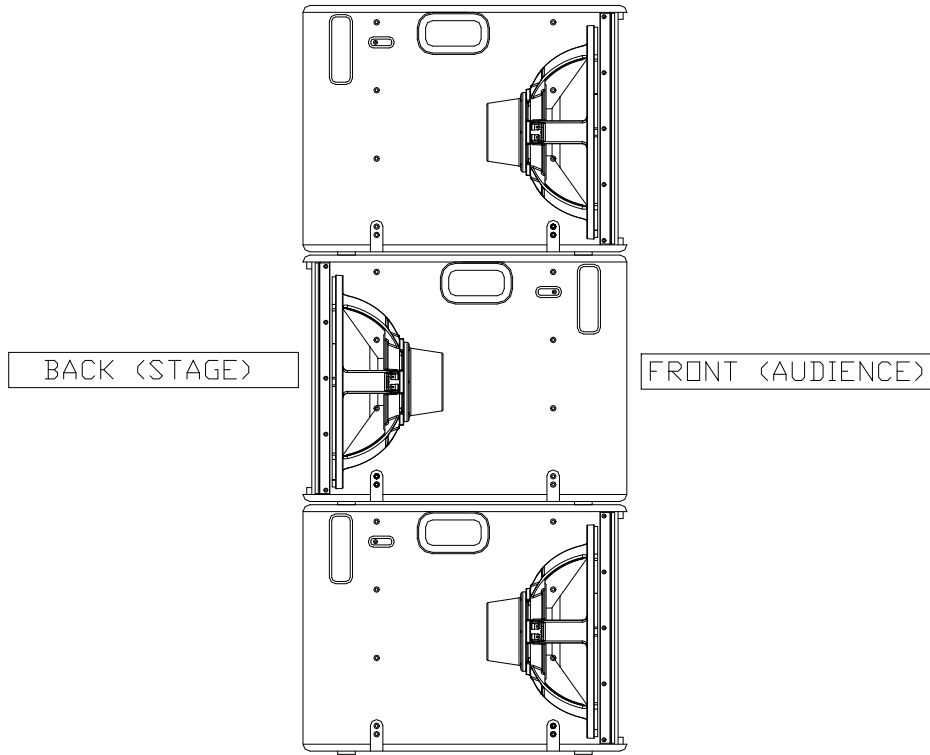

**Fig. 15.** Cardioid configuration for N18WP subwoofer

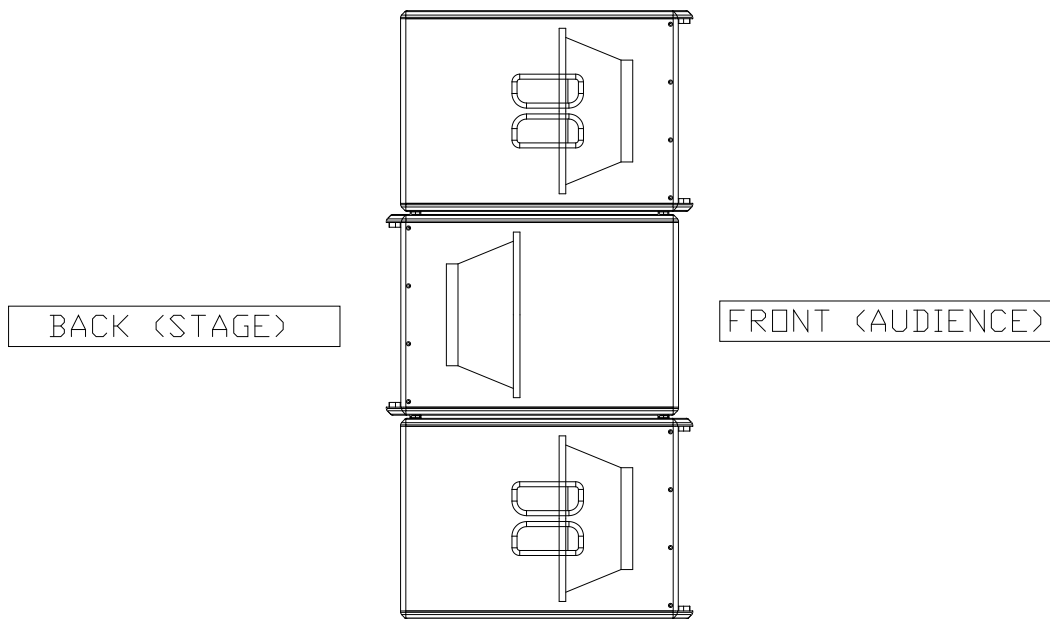

**Fig. 16.** Cardioid configuration for N12WP subwoofer

When using N218WP choose one of the following options:

- a) The front facing subwoofers must be driven with [LPF80] preset and the back facing subwoofer must be driven with [CARD80] preset.
- b) The front facing subwoofers must be driven with [LPF90] preset and the back facing subwoofer must be driven with [CARD90] preset.
- c) The front facing subwoofers must be driven with [LPF100] preset and the back facing subwoofer must be driven with [CARD100] preset.
- d) The front facing subwoofers must be driven with [LPF110] preset and the back facing subwoofer must be driven with [CARD110] preset.

**IMPORTANT NOTE: Due to the internal set-up of the cardioid presets, the threshold level (limiter) of the front facing subwoofers must be reduced by -3dB.**

When using N18WP choose one of the following options:

- a) The front facing subwoofers must be driven with [LPF80] preset and the back facing subwoofer must be driven with [CARD80] preset.
- b) The front facing subwoofers must be driven with [LPF90] preset and the back facing subwoofer must be driven with [CARD90] preset.
- c) The front facing subwoofers must be driven with [LPF100] preset and the back facing subwoofer must be driven with [CARD100] preset.
- d) The front facing subwoofers must be driven with [LPF110] preset and the back facing subwoofer must be driven with [CARD110] preset.
- e) The front facing subwoofers must be driven with [LPF120] preset and the back facing subwoofer must be driven with [CARD120] preset.

**IMPORTANT NOTE: Due to the internal set-up of the cardioid presets, the threshold level (limiter) of the back facing subwoofers using must be reduced by -1dB.**

When using N12W choose one of the following options:

- a) The front facing subwoofers must be driven with [LPF80] preset and the back facing subwoofer must be driven with [CARD80] preset.
- b) The front facing subwoofers must be driven with [LPF90] preset and the back facing subwoofer must be driven with [CARD90] preset.
- c) The front facing subwoofers must be driven with [LPF100] preset and the back facing subwoofer must be driven with [CARD100] preset.
- d) The front facing subwoofers must be driven with [LPF110] preset and the back facing subwoofer must be driven with [CARD110] preset.
- e) The front facing subwoofers must be driven with [LPF120] preset and the back facing subwoofer must be driven with [CARD120] preset.

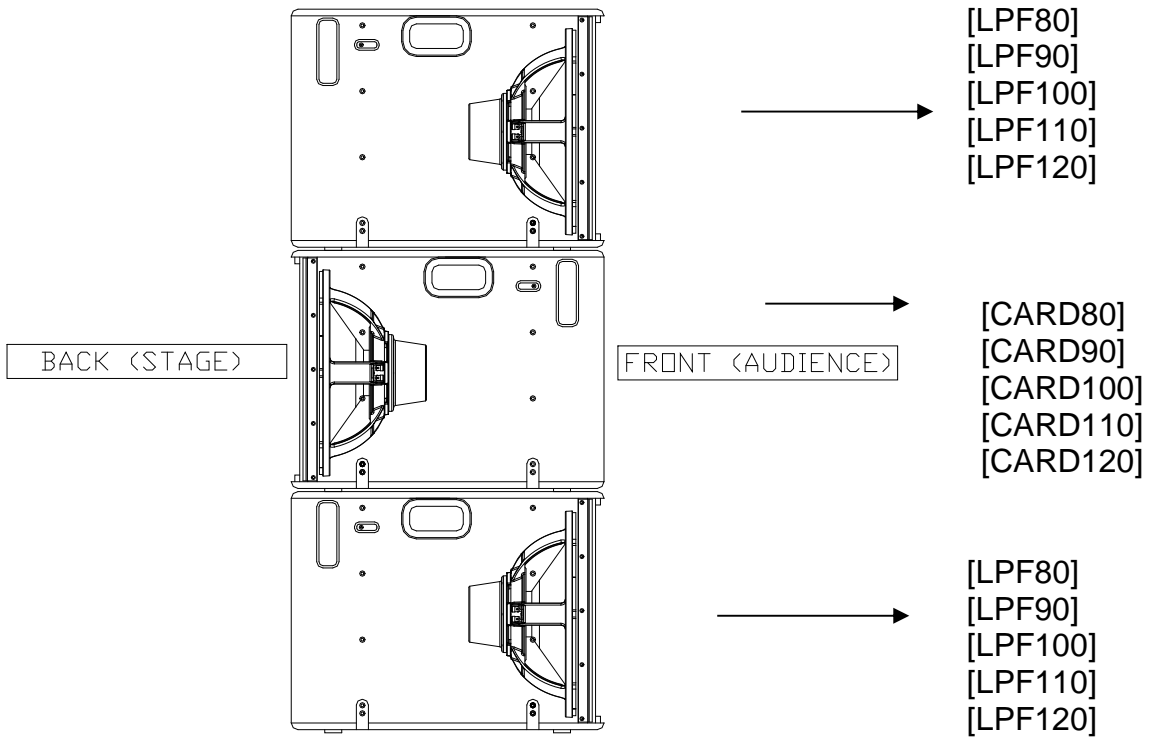

Fig. 17. Cardioid presets for N18WP subwoofer

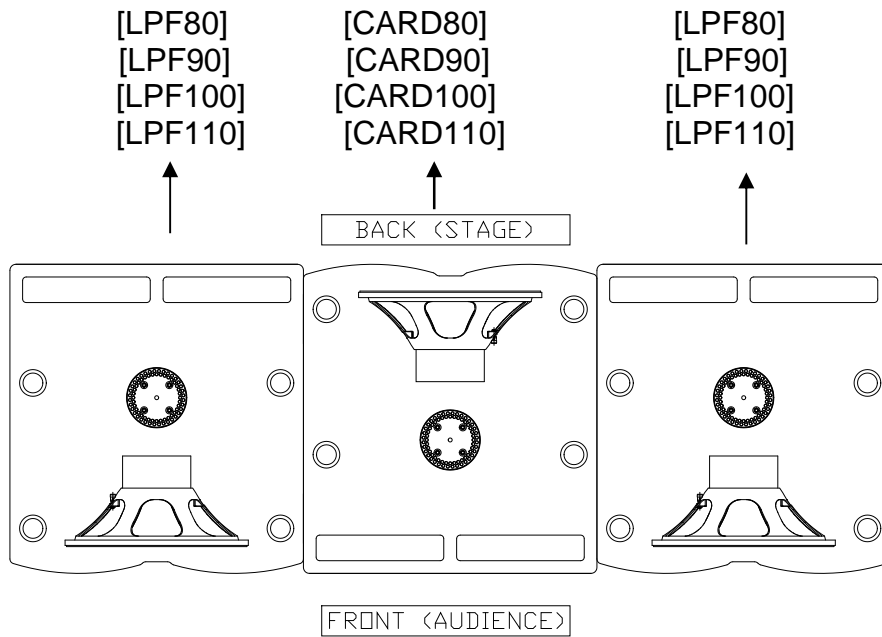
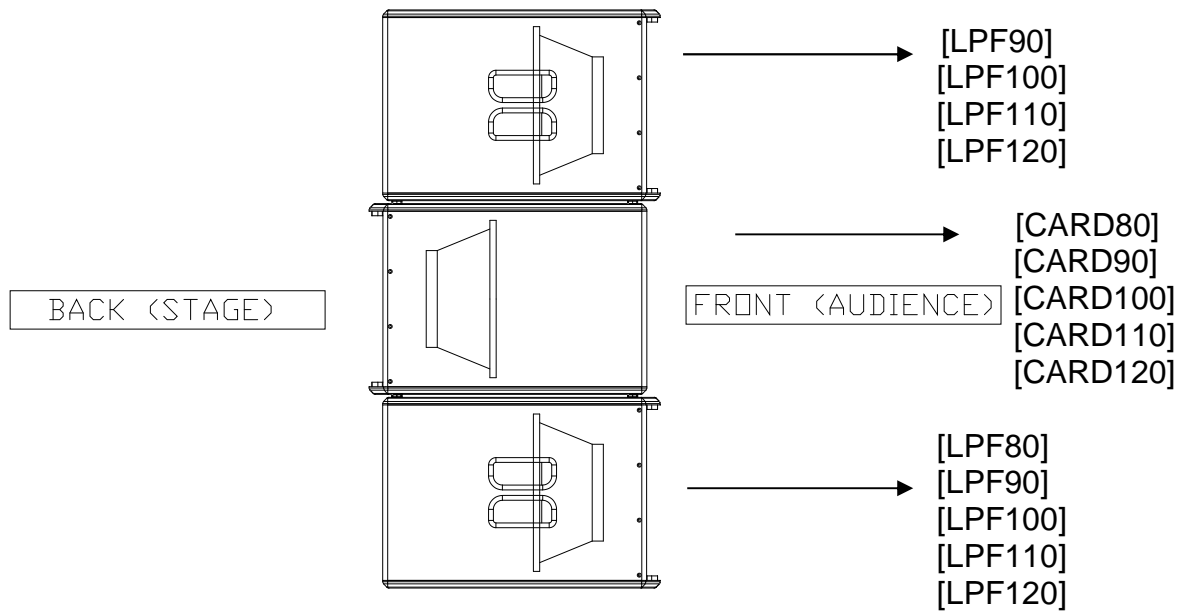

Fig. 18. Cardioid presets for N218WP subwoofer





**Fig. 19.** Cardioid presets for N12WP subwoofer

When placing the subwoofers in a cardioid configuration keep a distance to walls of at least 60 cm in order not to affect the radiation of the central reversed cabinet.

## 5. TECHNICAL FEATURES

	<b>N12WP</b>	<b>N18WP</b>	<b>N218WP</b>
<b>Impedance</b>			
Nominal	8	8	4
<b>Power</b>			
R.m.s	400 W	1200 W	2400 W
Program	800 W	2400 W	4800 W
Connectors	2 x Speakon NL4MPR input & link		1 x Speakon NL4MPR input
<b>Audio Performance</b>			
Frequency response (-10 dB usable bandwidth) with external DSP	38 Hz – 140 Hz	35 Hz – 150 Hz	30 Hz – 140 Hz
SPL (1W / 1m)	96 dB	98 dB	102 dB
Nominal directivity (-6dB)	Omnidirectional	Omnidirectional	Omnidirectional
<b>Components</b>			
LF	1 x 12" woofer (3" voice coil)	1 x 18" woofer (4" voice coil)	2 x 18" woofers (4" voice coil)
<b>Cabinet</b>			
Type	Bass-reflex	Bass-reflex	Bass-reflex
Height	384 mm	540 mm	1046 mm
Width	520 mm	664 mm	740 mm
Depth	552 mm	700 mm	780 mm
Weight (net)	24,9 Kg	49 Kg	96,8 Kg
Material	Multilayer birch plywood		
Finish	Hi-resistance black matt Polyurea coating. 1,5 mm steel front grilles with black acoustic mesh.	Hi-resistance black matt Polyurea coating. 2 mm steel front grilles with black acoustic mesh.	Hi-resistance black matt Polyurea coating. 2 mm steel front grilles with black acoustic mesh.

**Note:** Specifications subjected to change without prior notice.



*Great sound  
from Barcelona  
since 1972*

---

The **NITID** loudspeaker systems have been designed,  
engineered and manufactured in Barcelona – SPAIN  
by

---

**Amate Audio S.L.**

Perpinyà, 25 · Polígon Industrial Nord · 08226 Terrassa  
T. +34 93 735 65 65 – F. +34 93 735 60 48 –  
info@amateaudio.com

R&D and FACTORY:  
Violinista Vellsolà, 18 · 08222 Terrassa  
T. +34 93 736 23 90 – F. +34 93 786 47 00

**Barcelona – SPAIN**

---

[www.amateaudio.com](http://www.amateaudio.com)