



*Great sound  
from Barcelona  
since 1972*

[www.amateaudio.com](http://www.amateaudio.com)

# **User's manual** ***Manual de usuario***

# **UB-L**

**Universal wall-bracket**  
***Soporte pared universal***

June 2015

The UB-L is an optional accessory for wall mounting (horizontal orientation).  
*El UB-L es un accesorio opcional para el colgado en pared (horizontal).*

Locking screw (left)  
*Tornillo para bloqueo (izquierda)*

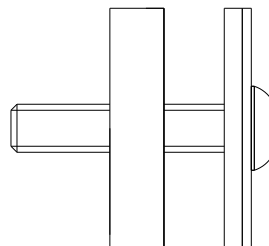

Locking block (right)  
*Cilindro para bloqueo (derecha)*

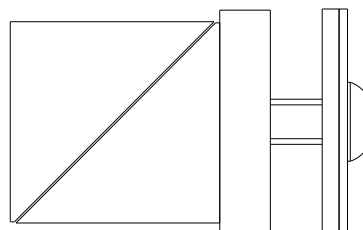

Bracket (left piece)  
*Soporte (pieza izquie)*

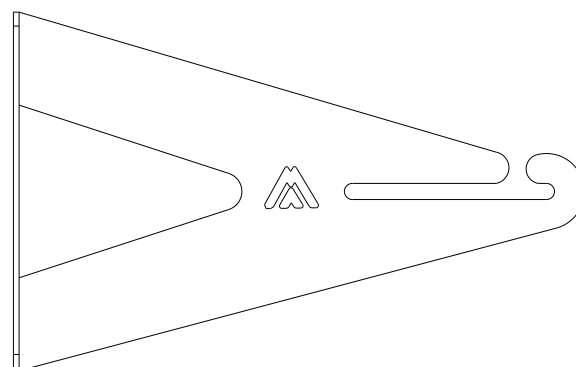
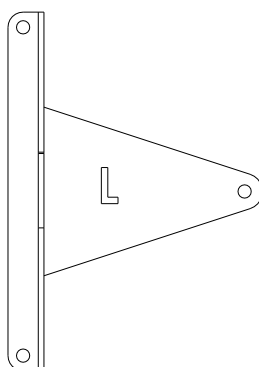

Bracket (right piece)  
*Soporte (pieza derecha)*

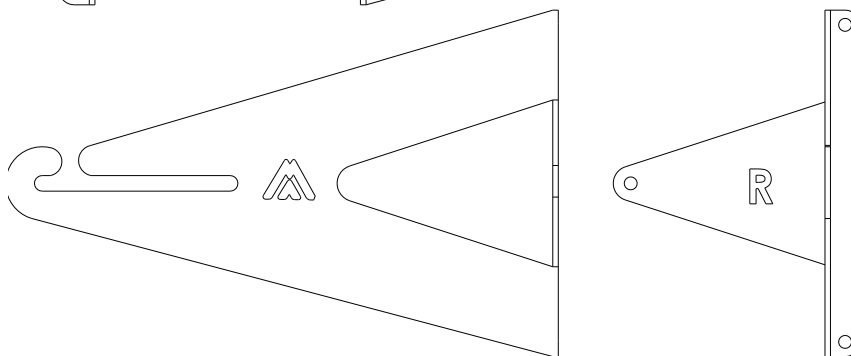

ALLEN tool  
*Herramienta ALLEN*



DIN7505B 5x30 screw (x6)  
*Tornillo DIN7505B 5x30 (x6)*

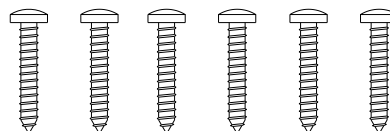

Fischer plug S6 (x6)  
*Taco Fischer S6 (x6)*

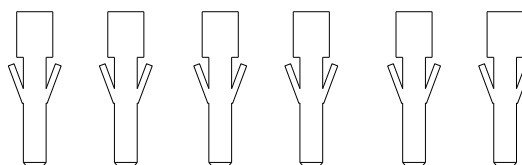

1- Put the locking block inside the 35-mm top hat's hole (except in JK12MA)  
*Coloque el cilindro dentro del agujero del vaso de 35mm (menos en la JK12MA)*

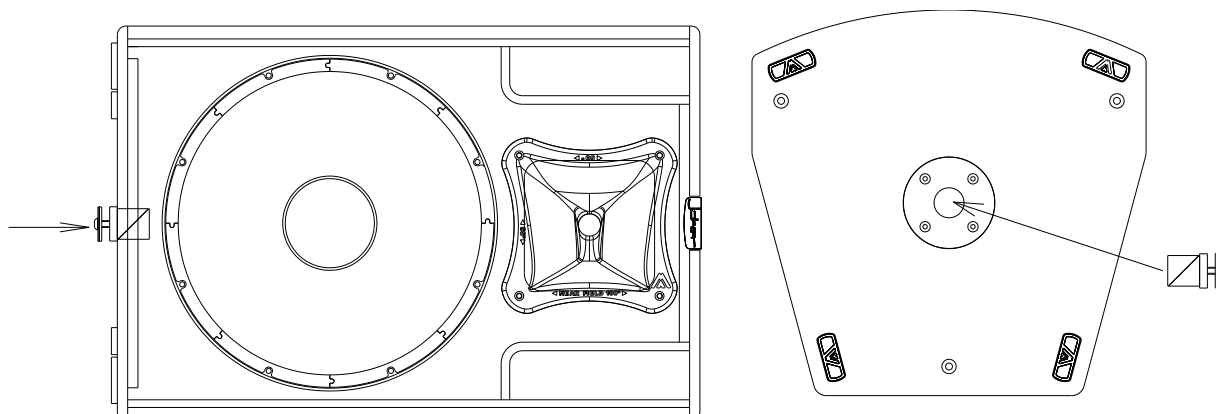

2- Remove the top M8 screw. Put the new locking screw  
*Quite el tornillo de M8 situado en la parte superior de la caja y coloque el tornillo para bloqueo*

JK26

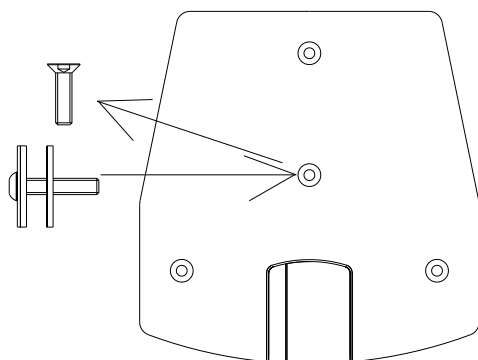

JK10

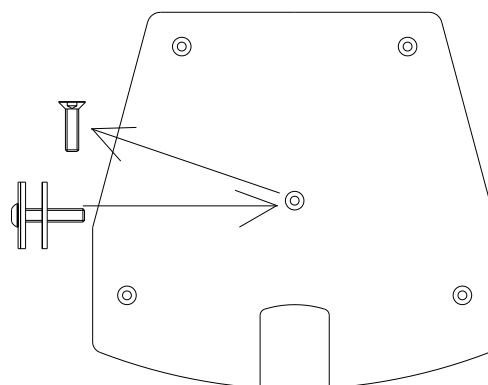

JK10MA

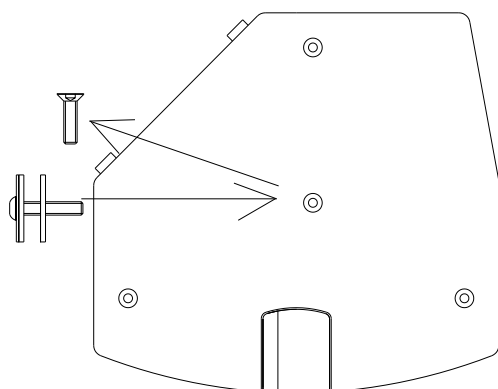

KEY10

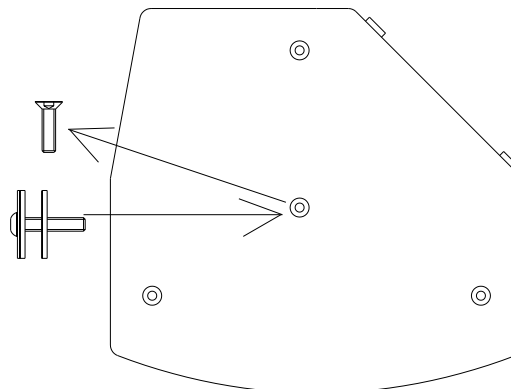

JK12

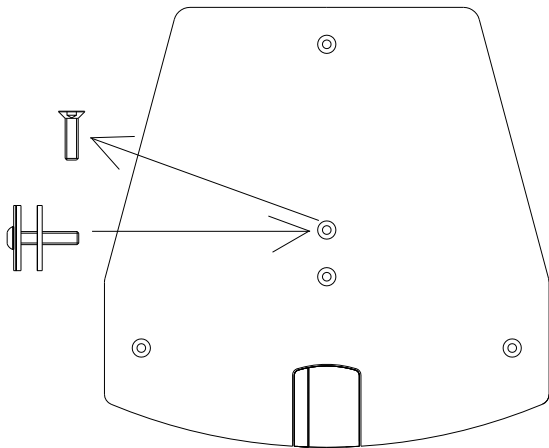

KEY12

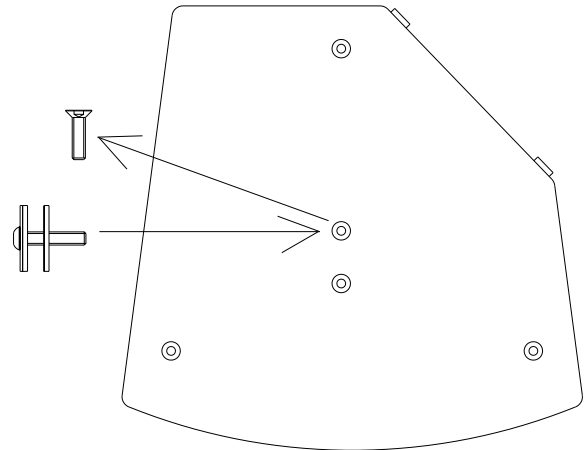

JK15

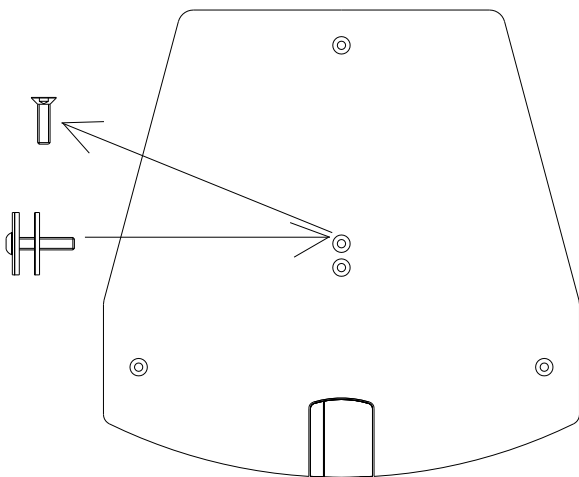

KEY15

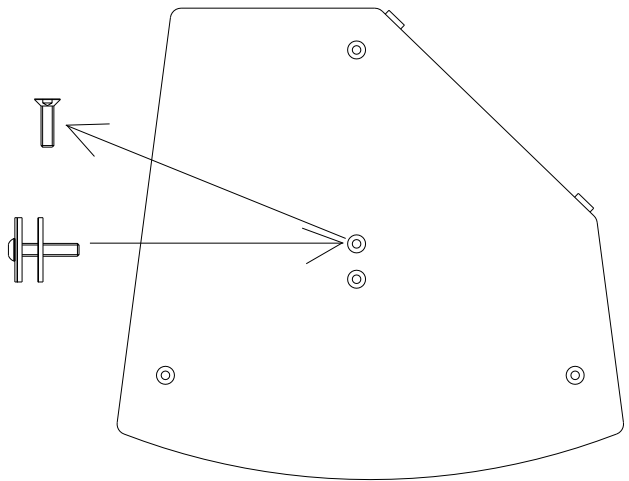

KEY8

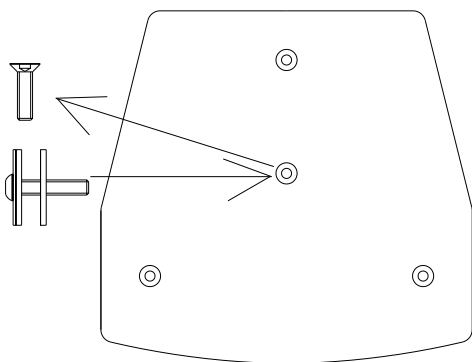

X15T/X15D

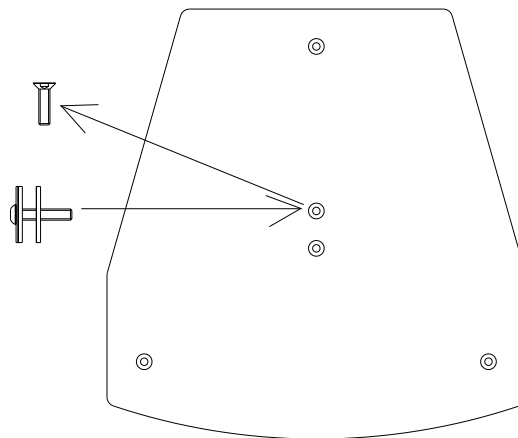

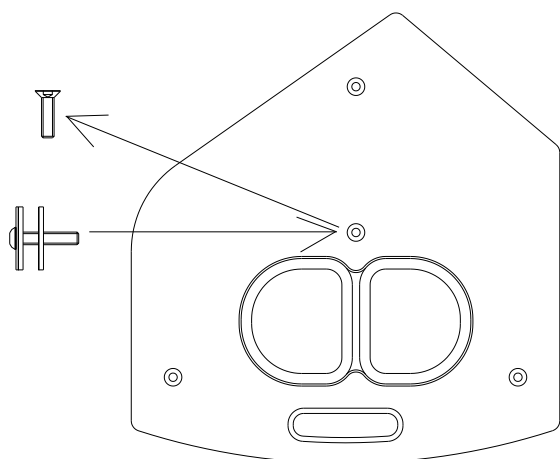
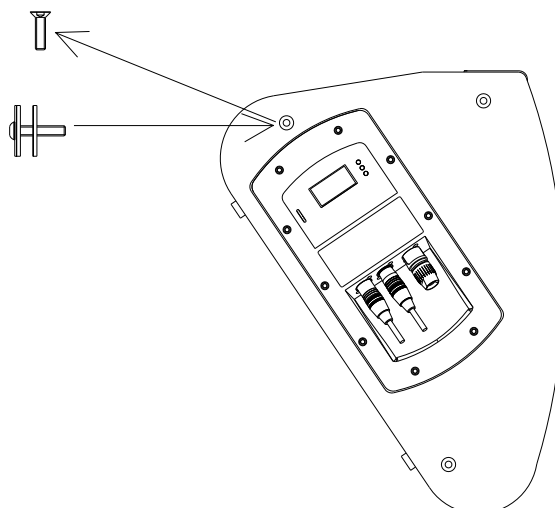
X14TJK12MA

3- Remove the screw from the locking block and place it on the following M8 hole (only in JK12MA)

*Desenrosque el cilindro de su eje y coloque el conjunto sobrante (tornillo y arandelas) en el punto indicado con una flecha (sólo para JK12MA)*

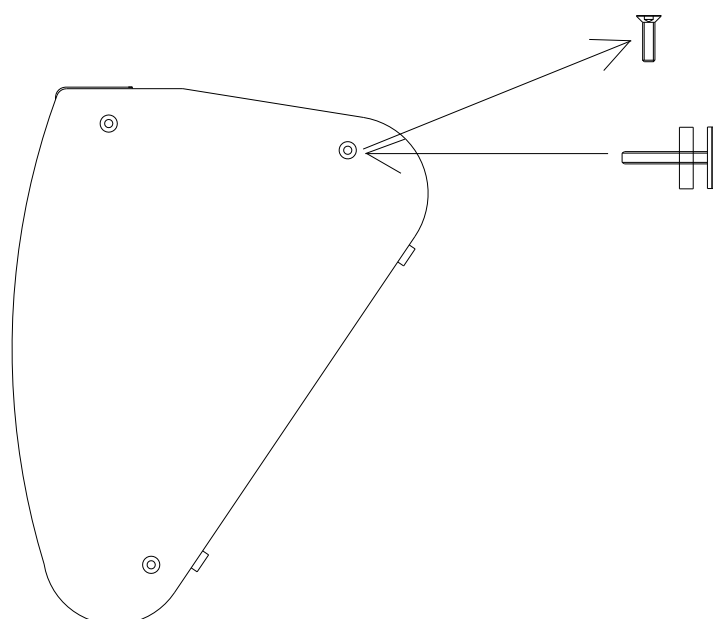
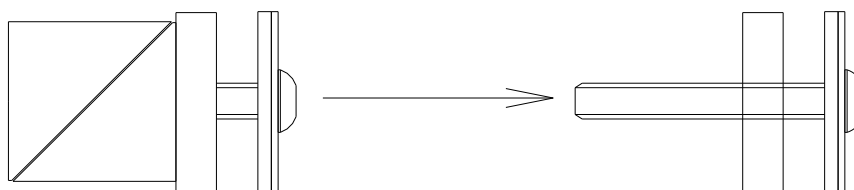

4- Set both ACRM8 eyebolts on the cabinet's M8 (i.e.1,2) fixing points (only if you have the SC15 security kit)

*Coloque las dos anillas ACRM8 en dos puntos de fijación de la caja (por ejemplo 1,2) para posteriormente, pasar la eslinga de seguridad (sólo en caso de disponer del "kit" opcional de seguridad SC15)*

### JK26

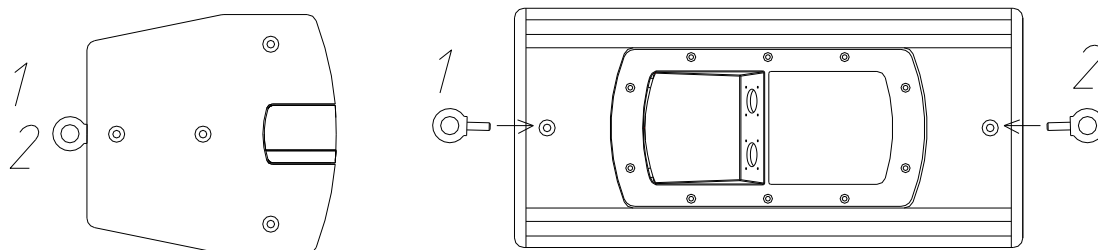

### JK10

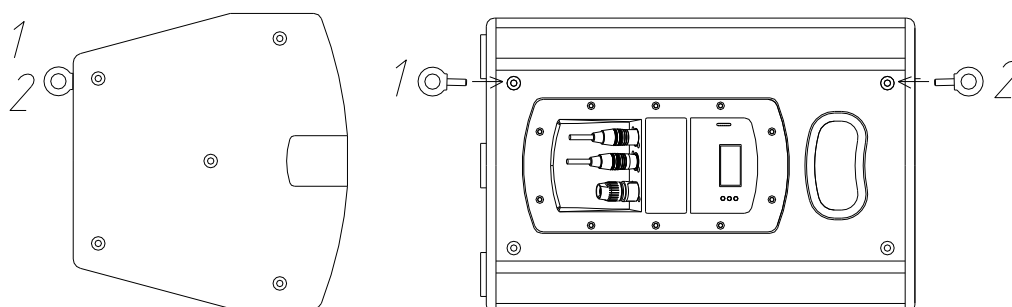

### JK10MA

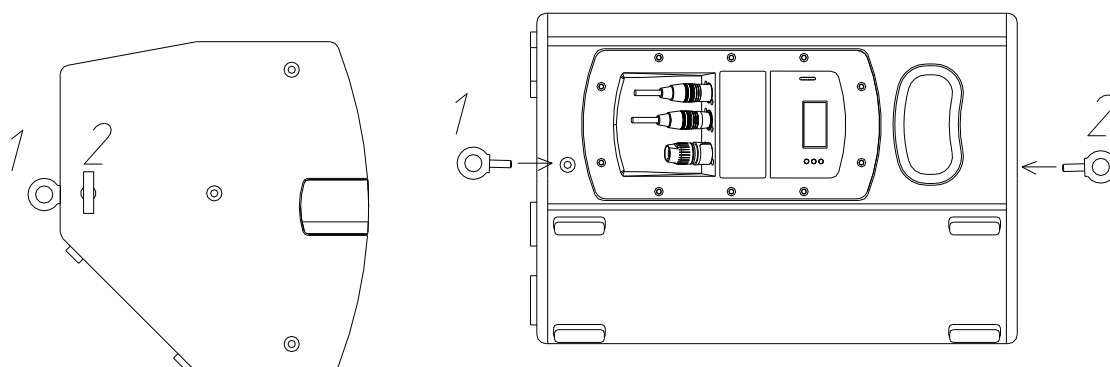

**KEY10**

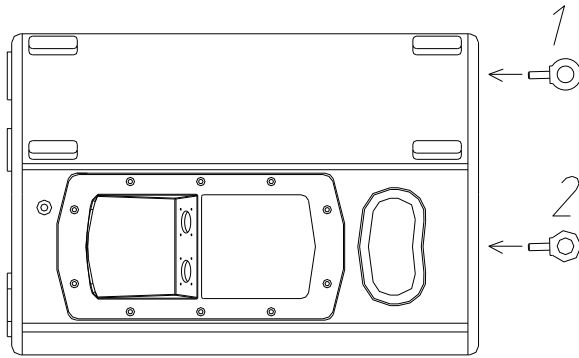
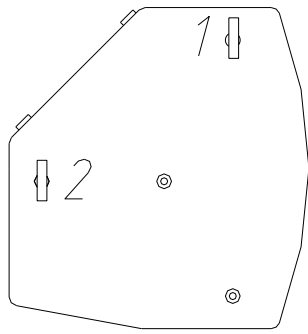

**JK12**

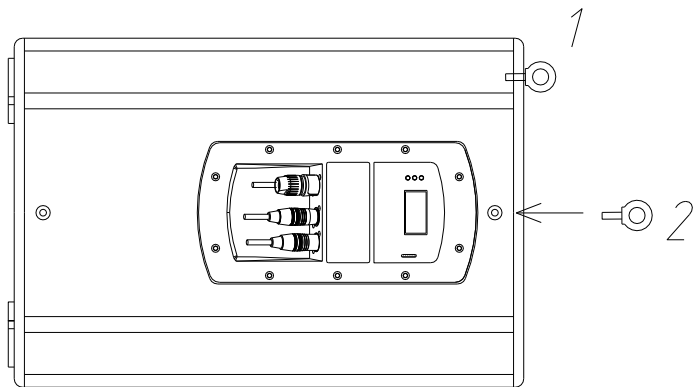
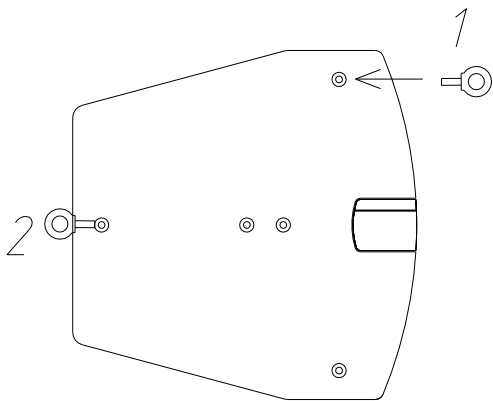

**KEY12**

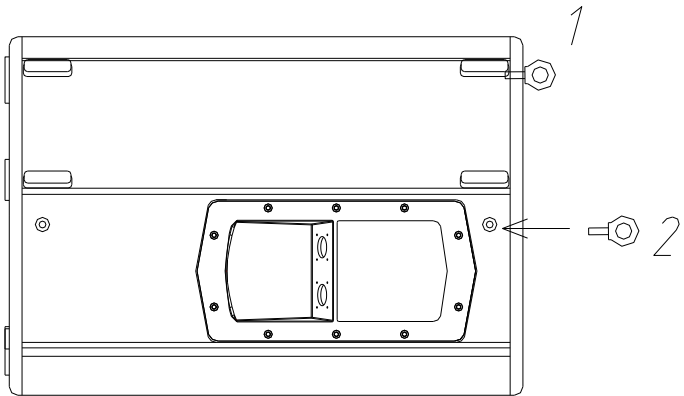
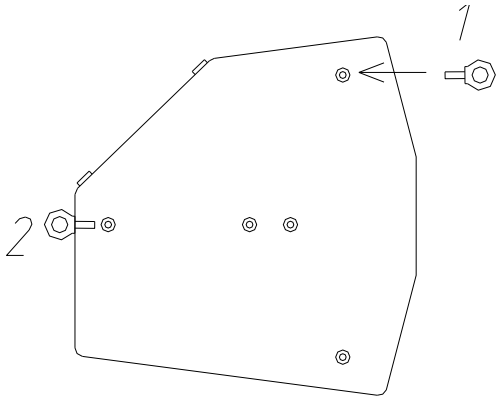

**JK15**

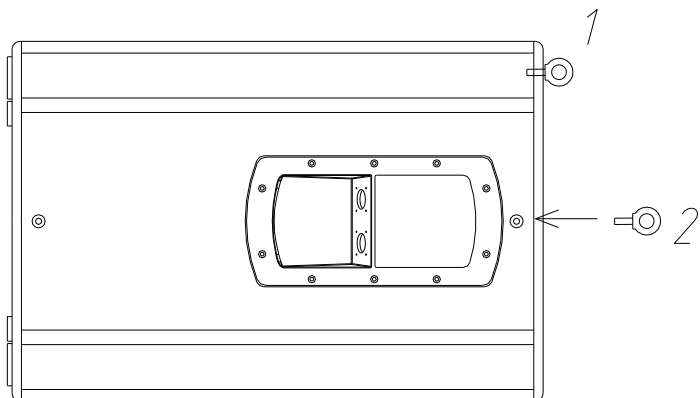
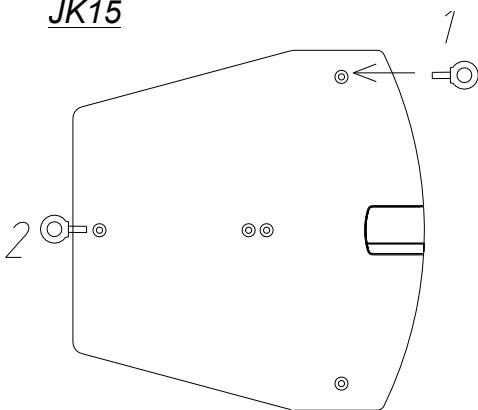

**KEY15**

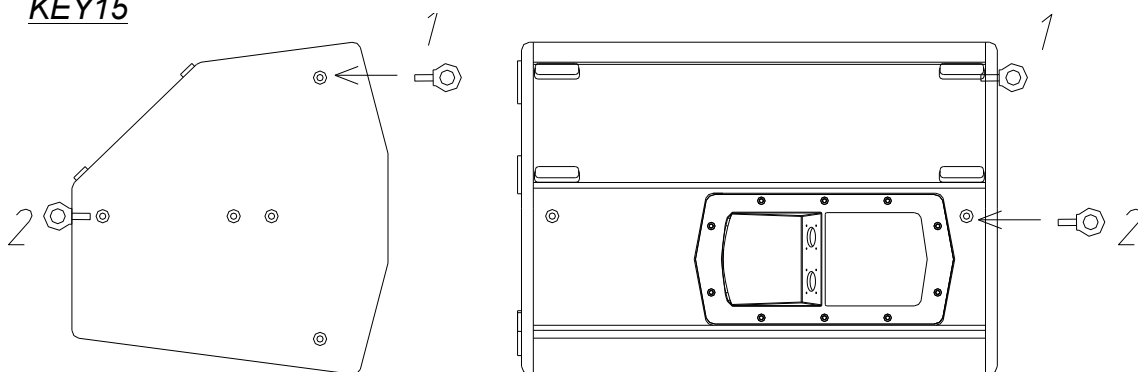

**KEY8**

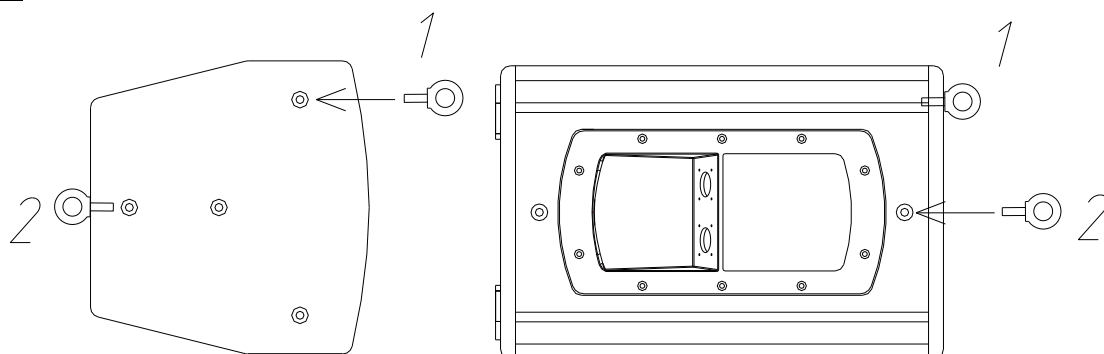

**X15T/X15D**

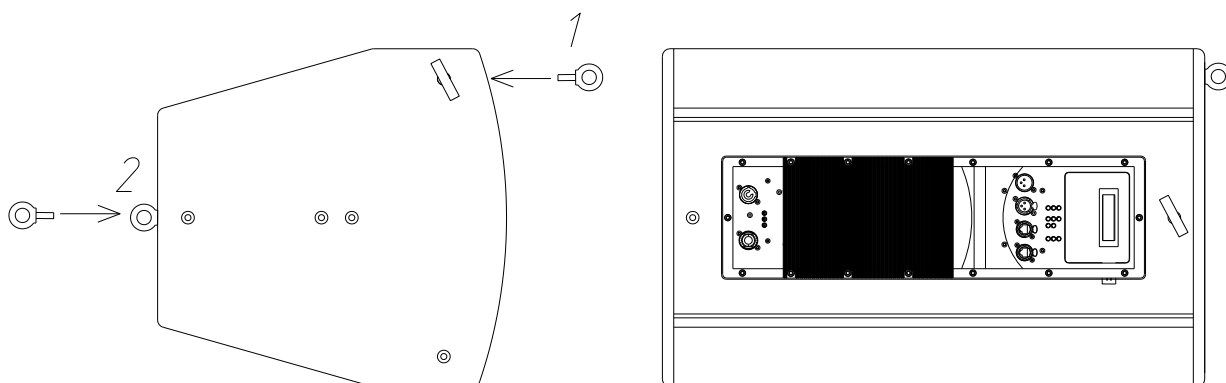

**X14T**

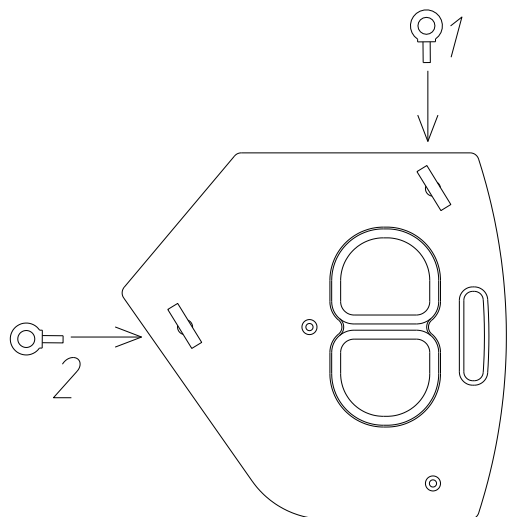

**JK12MA**

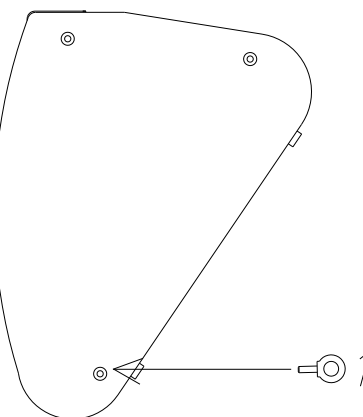



5- Place the supplied template on the wall and mark the fixing points in the correct location, according to each model.

*Coloque la plantilla de papel en la pared y marque los puntos de fijación (dependiendo de cada modelo)*

**KEY8 (463mm)**

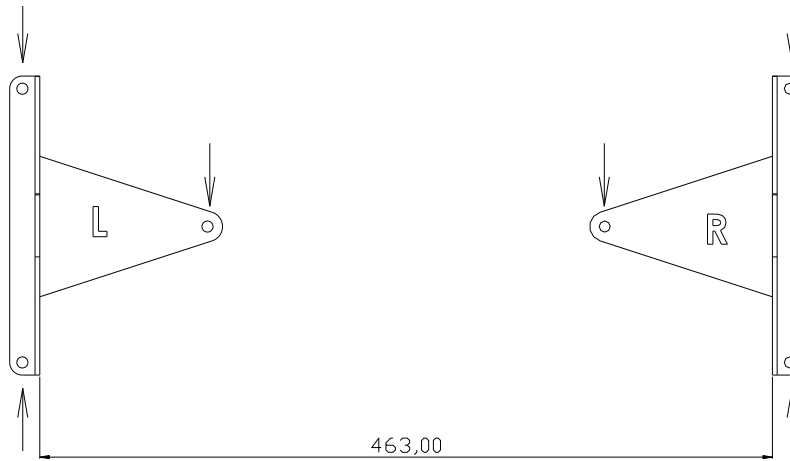

**KEY10 / JK26 / JK10 / JK10MA (548mm)**

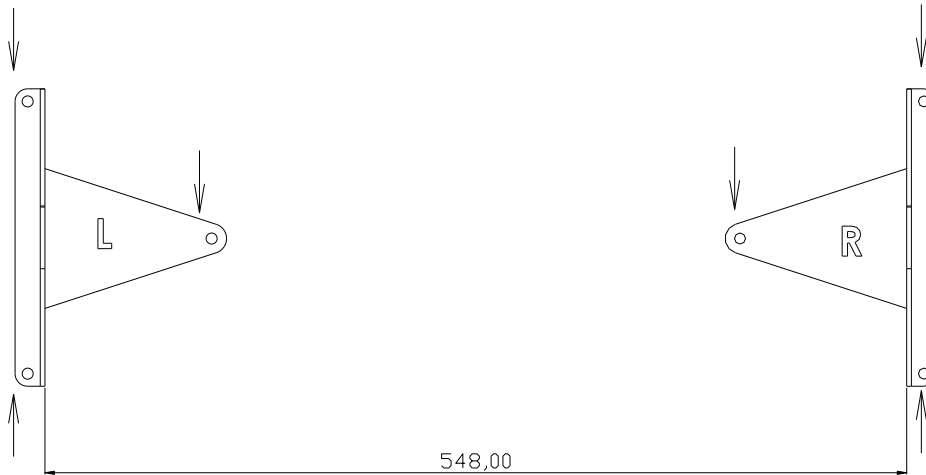

**KEY12 / JK12 / JK12MA (621mm)**

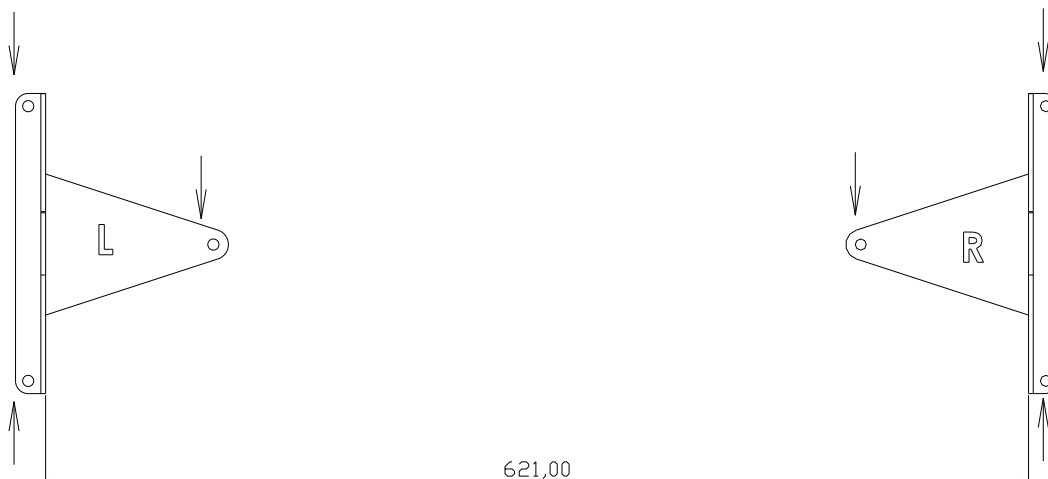

KEY15 / JK15 (701mm)

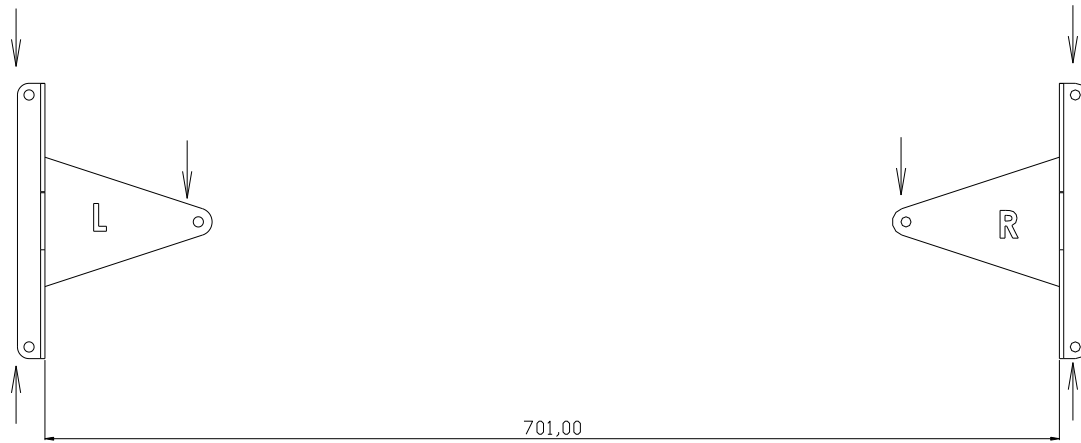

X15T/ X15D (733mm)

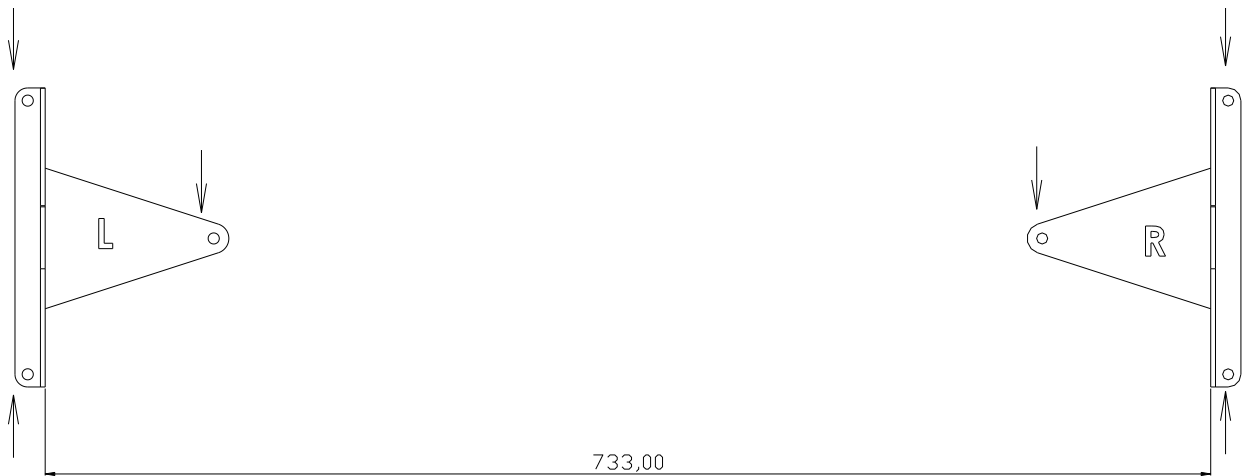

X14T (638mm)



6- Drill some corresponding pilot holes on the wall and fix the bracket using the wall plugs and the six DIN7505B 5x30 screws supplied in the kit

*Realice los taladros en la pared y cuelgue el soporte con tornillería adecuada y de alta resistencia (tacos M6 y tornillos DIN7505B 5x30 suministrados en el "kit")*

7- Place the cabinet on the bracket and fix it with both M8 screws (1)

*Coloque la caja entre el soporte y la pared y fijela con los dos tornillos de M8 (1)*

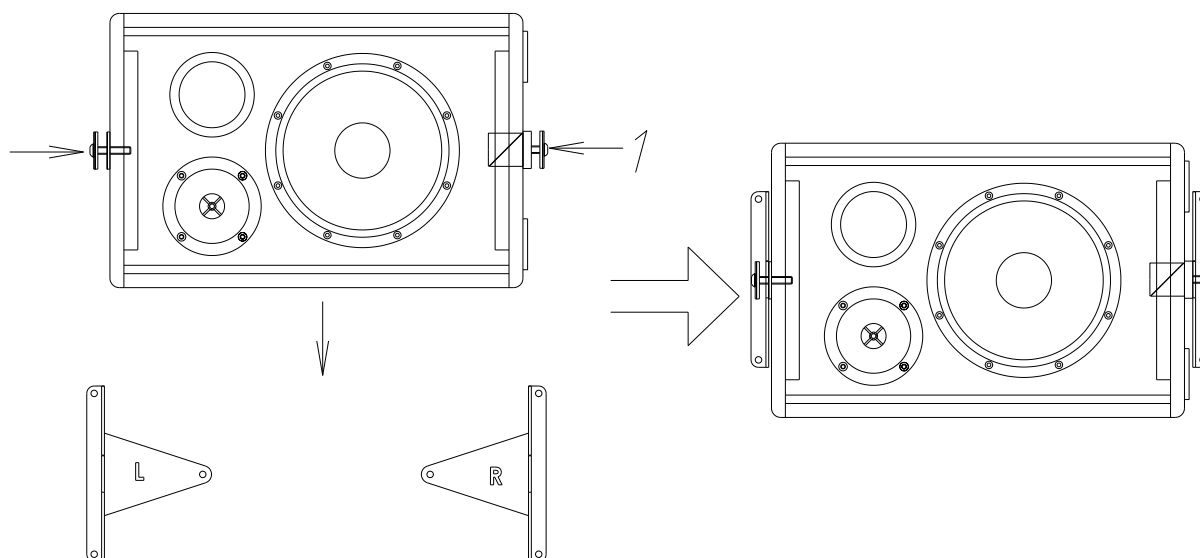

8- Choose the desired tilt angle and block the cabinet with the M8 lateral screws. Use the Allen tool.

*Dar la inclinación necesaria y bloquear con los tornillos laterales de M8. Use la llave Allen.*

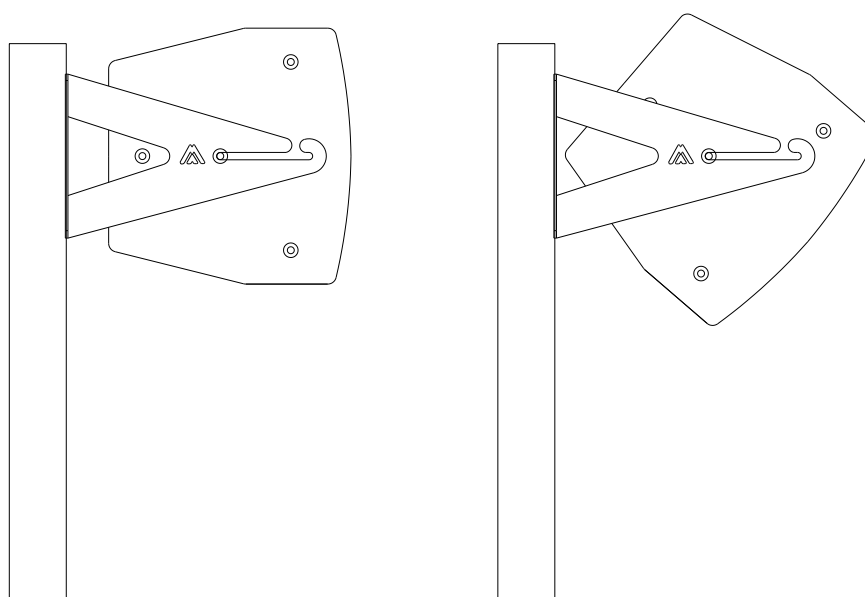

9- You can use the safety cable around the ACRM8 eyebolts. In this case, fix the safety cable on a secondary external point.

*Puede usar la eslinga como medida de seguridad adicional, colocándola por el interior de las anillas ACRM8. En este caso, la eslinga debe fijarse a un punto externo de carga.*

