

KRAMER



USER MANUAL

MODEL:

VM-4HDT

1:4 HDMI to HDBT DA



VM-4HDT Quick Start Guide

This guide helps you install and use your product for the first time. For more detailed information, go to <http://www.kramerav.com/manual/VM-4HDT> to download the latest manual or scan the QR code on the left.

Step 1: Check what's in the box

- The VM-4HDT 1:4 HDMI to HDBT DA
- 1 Quick start guide
- Bracket set for TOOLS
- 1 Power supply (5V DC)
- 4 Rubber feet

Step 2: Install the VM-4HDT

Attach the rubber feet and place on a table or mount the VM-4HDT in a rack (using an optional RK-T2B rack adapter).

Step 3: Connect inputs and outputs

Always switch OFF the power on each device before connecting it to your VM-4HDT. For best results, we recommend that you always use Kramer high-performance cables to connect AV equipment to the VM-4HDT.

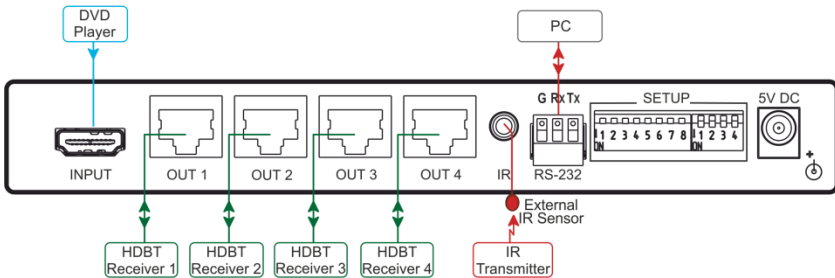

RJ-45 Pinout

For the Ethernet and HDBaseT connectors, see the proper wiring diagram below



EIA / TIA 568B	
PIN	Wire Color
1	Orange / White
2	Orange
3	Green / White
4	Blue
5	Blue / White
6	Green
7	Brown / White
8	Brown

For optimum range and performance use Kramer's BC-HDKat6a cable. This specially built cable significantly outperforms regular CAT 5 / CAT 6 cables.

Step 4: Connect the power

Connect the 5V DC power adapter to the rear of the **VM-4HDT** and connect the adapter to the mains electricity.

Step 5: Set the DIP-Switches

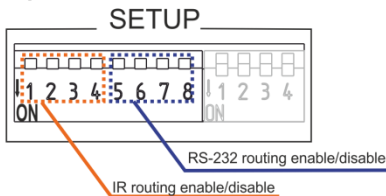

Output #	IR Routing is enabled when:	RS-232 Routing is enabled when:
OUT 1	DIP 1 – OFF	DIP 5 – OFF
OUT 2	DIP 2 – OFF	DIP 6 – OFF
OUT 3	DIP 3 – OFF	DIP 7 – OFF
OUT 4	DIP 4 – OFF	DIP 8 – OFF

For example, setting DIP 1 and 3 to OFF will enable IR signal routing via OUT 1 and OUT 3 while for OUT 2 and OUT 4 IR routing is disabled.

Step 6: Acquire the EDID

Press the EDID Setup button once to display the present EDID. Each additional press cycles through the EDID source options:

LEDs lit:	Chooses:
OUT 1	Output 1 EDID
OUT 2	Output 2 EDID
OUT 3	Output 3 EDID
OUT 4	Output 4 EDID
All LEDs flash	Default EDID

Stop pressing the EDID Setup button when the desired EDID source is lit.

Contents

1	Introduction	1
2	Getting Started	2
2.1	Achieving the Best Performance	2
2.2	Safety Instructions	3
2.3	Recycling Kramer Products	3
3	Overview	4
3.1	About HDBaseT™ Technology	5
3.2	Using Twisted Pair Cable for HDBT	5
3.3	Defining the VM-4HDT 1:4 HDMI to HDBT DA	6
4	Connecting the VM-4HDT	7
5	Operating the VM-4HDT	9
5.1	IR and RS-232 Signal Routing	9
5.2	Acquiring an EDID	13
6	Default EDID	14
7	Technical Specifications	16
7.1	Default Communication Parameters	16
8	Protocol 3000	17
8.1	Kramer Protocol 3000 Syntax	17
8.2	Kramer Protocol 3000 Commands	20
8.3	Kramer Protocol 3000 – Detailed Commands	20
Figures		
Figure 1:	VM-4HDT 1:4 HDMI to HDBT DA	6
Figure 2:	Connecting the VM-4HDT 1:4 HDMI to HDBT DA	8
Figure 3:	VM-4HDT DIP-Switches	9
Figure 4:	VM-4HDT DIP-Switches Setup	10
Figure 5:	IR/RS-232 Routing Example	12

1 Introduction

Welcome to Kramer Electronics! Since 1981, Kramer Electronics has been providing a world of unique, creative, and affordable solutions to the vast range of problems that confront the video, audio, presentation, and broadcasting professional on a daily basis. In recent years, we have redesigned and upgraded most of our line, making the best even better!

Our 1,000-plus different models now appear in 14 groups that are clearly defined by function: GROUP 1: Distribution Amplifiers; GROUP 2: Switchers and Routers; GROUP 3: Control Systems; GROUP 4: Format/Standards Converters; GROUP 5: Range Extenders and Repeaters; GROUP 6: Specialty AV Products; GROUP 7: Scan Converters and Scalers; GROUP 8: Cables and Connectors; GROUP 9: Room Connectivity; GROUP 10: Accessories and Rack Adapters; GROUP 11: Sierra Video Products; GROUP 12: Digital Signage; GROUP 13: Audio; and GROUP 14: Collaboration.

Congratulations on purchasing your Kramer **VM-4HDT** 1:4 HDMI to HDBT DA, which is ideal for the following typical applications:

- Boardrooms and meeting rooms
- Presentation and multimedia applications
- Broadcast
- Rental and staging

2 Getting Started

We recommend that you:

- Unpack the equipment carefully and save the original box and packaging materials for possible future shipment
- Review the contents of this user manual



Go to <http://www.kramerav.com/downloads/VM-4HDT> to check for up-to-date user manuals, application programs, and to check if firmware upgrades are available (where appropriate).

2.1 Achieving the Best Performance

To achieve the best performance:

- Use only good quality connection cables (we recommend Kramer high-performance, high-resolution cables) to avoid interference, deterioration in signal quality due to poor matching, and elevated noise levels (often associated with low quality cables)
- Do not secure the cables in tight bundles or roll the slack into tight coils
- Avoid interference from neighbouring electrical appliances that may adversely influence signal quality
- Position your Kramer **VM-4HDT** away from moisture, excessive sunlight and dust



This equipment is to be used only inside a building. It may only be connected to other equipment that is installed inside a building.

2.2 Safety Instructions



Caution: There are no operator serviceable parts inside the unit

Warning: Use only the Kramer Electronics input power wall adapter that is provided with the unit

Warning: Disconnect the power and unplug the unit from the wall before installing

2.3 Recycling Kramer Products

The Waste Electrical and Electronic Equipment (WEEE) Directive 2002/96/EC aims to reduce the amount of WEEE sent for disposal to landfill or incineration by requiring it to be collected and recycled. To comply with the WEEE Directive, Kramer Electronics has made arrangements with the European Advanced Recycling Network (EARN) and will cover any costs of treatment, recycling and recovery of waste Kramer Electronics branded equipment on arrival at the EARN facility. For details of Kramer's recycling arrangements in your particular country go to our recycling pages at <http://www.kramerelectronics.com/support/recycling/>.

3 Overview

The Kramer MegaTOOLS® **VM-4HDT** is a high-quality 1:4 HDMI to HDBT DA that takes one HDMI input, equalizes and reclocks the signal and distributes it to four identical HDBT outputs. The **VM-4HDT** distributes signals having resolutions up to 4Kx2K and including WUXGA and 1080p.

In particular, the **VM-4HDT** features:

- A maximum data rate of 10.2Gbps (3.4Gbps per graphic channel)
- HDMI support for 3D, Deep Color, x.v.Color™, Lip Sync, HDMI Uncompressed Audio Channels, Dolby TrueHD, DTS-HD, CEC (only for OUT 1)
- HDCP compliance (note that sources that support HDCP will output HDCP protected content)
- Kramer Equalization & re-Klocking™ Technology that rebuilds the digital signal integrity to travel longer distances
- I-EDIDPro™ Kramer Intelligent EDID Processing™, an intelligent EDID handling and processing algorithm that ensures Plug and Play operation for HDMI systems
- A default EDID for fast and efficient connection of the unit
The default EDID feature lets you connect the **VM-4HDT** without having to connect a display to the output
- Support for EDID Designer via the USB port
- 3D pass-through
- A 5V DC power source
- A MegaTOOLS® sized enclosure. two devices can be mounted in a 1U rack space using the optional **RK-T2B** adapter

The **VM-4HDT** supports a range of up to 70m (230ft) at 2K resolutions and 40m (130ft) at 4K resolutions (on shielded **BC-HDKat6a** cable).

3.1 About HDBaseT™ Technology

HDBaseT™ is an advanced all-in-one connectivity technology (supported by the HDBaseT Alliance). It is particularly suitable in the ProAV – and also the home – environment as a digital networking alternative, where it enables you to replace numerous cables and connectors by a single LAN cable used to transmit, for example, uncompressed full high-definition video, audio, IR, as well as various control signals.



The products described in this user manual are HDBaseT certified.

3.2 Using Twisted Pair Cable for HDBT

Kramer engineers have developed special twisted pair cables to best match our digital twisted pair products; **BC-HDKat6a** (CAT 6 23 AWG cable) significantly outperforms regular CAT 5 / CAT 6 cables.



We strongly recommend that you use shielded twisted pair cable.

3.3 Defining the VM-4HDT 1:4 HDMI to HDBT DA

Figure 1 defines the **VM-4HDT**.

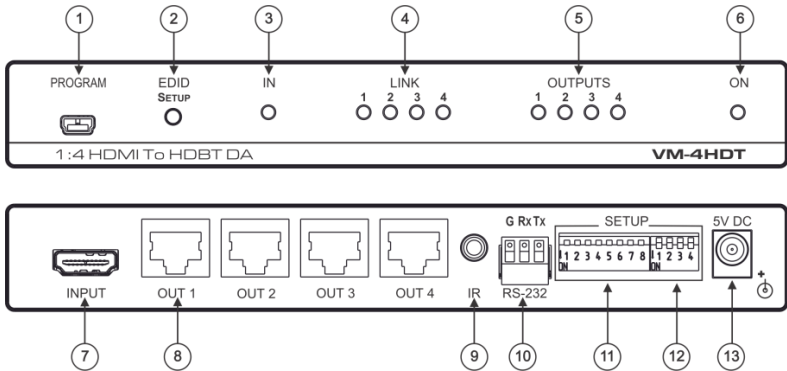

Figure 1: VM-4HDT 1:4 HDMI to HDBT DA

#	Feature	Function
1	PROGRAM Mini USB Connector	Use to send RS-232 Commands (see Section 8.3). Connect to a PC to perform firmware upgrades (via K-Upload) and work with the EDID Designer. K-Upload and EDID Designer can be downloaded from our Web site at: http://www.kramerav.com/manual/EDID_Designer
2	EDID SETUP Button	Press to capture the input EDID or select the default EDID (see Section 5)
3	IN LED	Lights when an active input signal is detected
4	LINK LEDs	Lights when a link is established with the receiver (from 1 to 4)
5	OUTPUT LEDs	Lights when an active output acceptor is detected (from 1 to 4)
6	ON LED	Lights when the unit receives power
7	INPUT HDMI Connector	Connects to the HDMI source
8	HDBT OUT Connectors	Connect to an HDBT acceptor (from 1 to 4), for example TP-580R
9	IR 3.5mm Mini Jack	Connect to the remote IR sensor/emitter
10	RS-232 CONTROL 3-pin Terminal Block	Connect to the serial controller to send RS-232 data to remote receiver
11	SETUP 8-way DIP-switch	Used to set the IR and RS-232 commands behavior, (see Section 5.1.1)
12	SETUP 4-way DIP-switch	For future use
13	5V DC Connector	Connects to the 5V DC power supply

4 Connecting the VM-4HDT



Always switch off the power to each device before connecting it to your **VM-4HDT**. After connecting your **VM-4HDT**, connect its power and then switch on the power to each device.

Connect the **VM-4HDT** as illustrated in the example in [Figure 2](#):

1. Connect an HDMI input source (for example, a BluRay disk player) to the HDMI IN connector.
2. Connect the four HDBT outputs to up to four HDBT receivers (for example, The **TP-580R** and the **TP-588D**).



Note that If a mac is connected as a source and a non-HDCP is connected as the acceptor, the signal will not pass.

3. Connect the 5V DC power adapter to the power socket unit and then connect the adapter to the mains electricity (not shown in [Figure 2](#)). The ON LED lights.

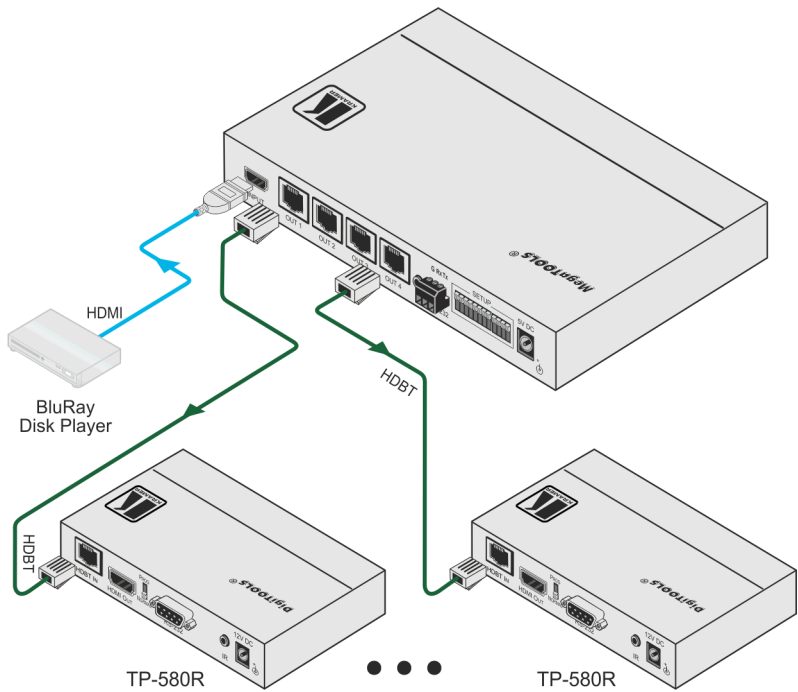

Figure 2: Connecting the VM-4HDT 1:4 HDMI to HDBT DA

5 Operating the VM-4HDT

This section describes how IR and RS-232 signals are routed (see [Section 5.1](#)) and how to acquire the EDID (see [Section 5.2](#)).

5.1 IR and RS-232 Signal Routing

The **VM-4HDT** can send or receive IR and RS-232 commands via the four HDBT output ports.

Each signal can pass commands from the **VM-4HDT** to a single output, several outputs or all of the outputs or the other way around, from the output/s to the **VM-4HDT**.

The IR/RS-232 signal routing is set via the SETUP DIP-switches (see [Section 5.1.1](#))

5.1.1 Setting the DIP-Switches

[Figure 3](#) defines the SETUP DIP-Switches:

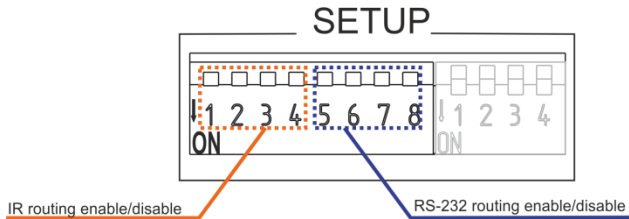

Figure 3: VM-4HDT DIP-Switches

The setup is defined in the table below:

Output #	IR Routing is enabled when:	RS-232 Routing is enabled when:
OUT 1	DIP 1 – OFF	DIP 5 – OFF
OUT 2	DIP 2 – OFF	DIP 6 – OFF
OUT 3	DIP 3 – OFF	DIP 7 – OFF
OUT 4	DIP 4 – OFF	DIP 8 – OFF

For example, in the DIP-switch setup shown in [Figure 4](#), DIPs 1, 4, 7 and 8 are set to OFF. This means that IR signals can be transferred through channels 1 and 4 and RS-232 commands can be passed via channels 3 and 4. All the other channels are set to ON and are therefore disabled.

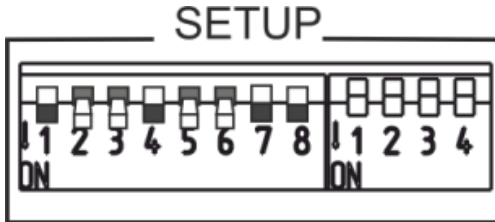

Figure 4: VM-4HDT DIP-Switches Setup

5.1.2 Signal Routing

The example in [Figure 5](#) shows the **VM-4HDT** connected to four **TP-580R** devices. The table below summarizes the types of connections:

Output #	HDMI OUT:	INPUT	IR	RS-232
VM-4HDT		BluRay Disk player	Emitter	PC
TP-580R (1)	Display		Sensor	
TP-580R (2)	Display		Sensor	
TP-580R (3)	Projector		Sensor	Projector
TP-580R (4)	Projector		Sensor	Projector

IR signal Routing

To route the IR signal you have to use the Kramer external IR sensor on one end (P/N: 95-0104050) and the Kramer IR emitter cable on the other end (P/N: C-A35/IRE-10). Note that two IR Emitter Extension Cables are available: a 15 meter cable and a 20 meter cable

In this example, an IR emitter is connected to the streamer and IR sensors are connected to all the **TP-580R** devices. This setup lets you remotely control the streamer via any of the receiver devices using the streamer's IR remote control transmitter.

RS-232 Signal Routing

A laptop can be used to control the product via mini USB port and **K-TOUCH** can be used to send RS-232 commands over HDBaseT to the remote connected device.

In this example, a laptop is connected to the RS-232 terminal block connector on the **VM-4HDT** and the RS-232 ports on **TP-580R** (3) and **TP-580R** (4) are connected to the projector. This type of setup allows you to control the Projectors.

RS-232 commands are sent to both projectors:

- If they are of the same model (for example, both are Projector A), both will respond to these commands
- If they are not of the same make (Projector A and Projector B) The Projector A commands will affect only Projector A and will be ignored by Projector B

In the same way, if the RS-232 are also connected to the displays on **TP-580R** (1) and **TP-580R** (2) they can also receive specific commands each, which will be ignored by devices of a different make.

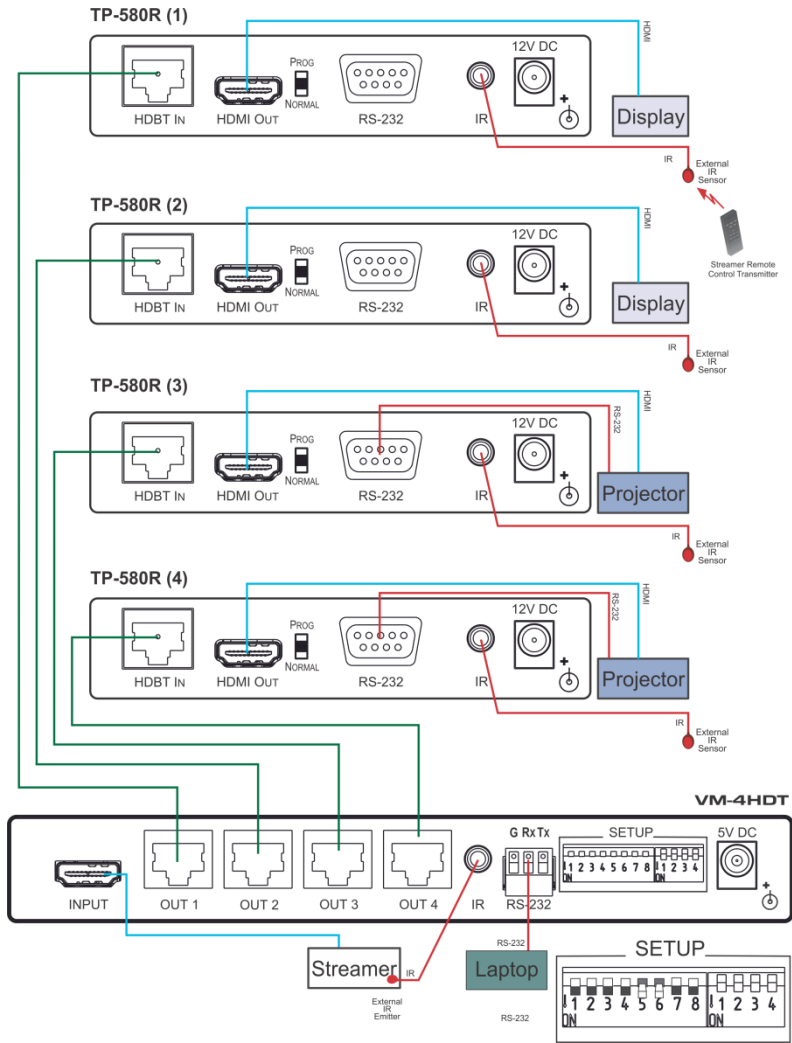

Figure 5: IR/RS-232 Routing Example

5.2 Acquiring an EDID

To acquire an EDID, press the EDID SETUP button as follows:

1. The first press of the EDID SETUP button displays the present EDID status similar to that shown in the next step.
2. The second press of EDID SETUP enters the read mode and each additional press cycles through the source options:
OUT 1 -> OUT 2 -> OUT 3 -> OUT 4 -> all LEDs flash for a default EDID.
3. When the desired EDID source is reached, release the EDID SETUP button. The **VM-4HDT** reads the EDID for a few seconds. When finished, all LEDs return to display the present output connection status.



Note that if an unconnected output is chosen or the EDID cannot be read, the **VM-4HDT** loads the default EDID



Note that **VM-4HDT** Supports EDID Designer (via the mini USB port) that can be loaded from our Web site: [Kramer EDID Designer](#)

Note that in order to use the mini USB port, you need to download and the Kramer USB driver from our Web site at: http://www.kramerelectronics.com/support/product_downloads.asp and install it

5.2.1 Forcing the RGB Mode

If you want to force the EDID, that the source is seeing, to support only RGB color space, press and hold the EDID button until all the output LEDs flash together, and then read the desired EDID.

To return to the normal mode press and hold the EDID button until the output LEDs light together and then read the desired EDID.

6 Default EDID

Model name..... VM-4HDT
Manufacturer..... KMR
Plug and Play ID..... KMR0672
Data string..... Default-EDID
Serial number..... 2
Manufacture date..... 2012, ISO week 255
Filter driver..... None

EDID revision..... 1.3
Input signal type..... Digital
Color bit depth..... Undefined
Display type..... RGB color
Screen size..... 520 x 320 mm (24.0 in)
Power management..... Standby, Suspend, Active off/sleep
Extension blocs..... 1 (CEA-EXT)

DDC/CI..... Not supported

Color characteristics
Default color space..... Non-sRGB
Display gamma..... 2.20
Red chromaticity..... Rx 0.674 - Ry 0.319
Green chromaticity..... Gx 0.188 - Gy 0.706
Blue chromaticity..... Bx 0.148 - By 0.064
White point (default).... Wx 0.313 - Wy 0.329
Additional descriptors... None

Timing characteristics
Horizontal scan range.... 30-83kHz
Vertical scan range..... 56-76Hz
Video bandwidth..... 170MHz
CVT standard..... Not supported
GTF standard..... Not supported
Additional descriptors... None
Preferred timing..... Yes
Native/preferred timing.. 1280x720p at 60Hz (16:9)
Modeline..... "1280x720" 74.250 1280 1390 1430 1650 720 725 730 750 +hsync +vsync

Standard timings supported
720 x 400p at 70Hz - IBM VGA
640 x 480p at 60Hz - IBM VGA
640 x 480p at 75Hz - VESA
800 x 600p at 60Hz - VESA
800 x 600p at 75Hz - VESA
1024 x 768p at 60Hz - VESA
1024 x 768p at 75Hz - VESA
1280 x 1024p at 75Hz - VESA
1280 x 1024p at 60Hz - VESA STD
1600 x 1200p at 60Hz - VESA STD
1152 x 864p at 75Hz - VESA STD

EIA/CEA-861 Information
Revision number..... 3
IT underscan..... Supported
Basic audio..... Supported
YCbCr 4:4:4..... Supported
YCbCr 4:2:2..... Supported
Native formats..... 1
Detailed timing #1..... 1920x1080p at 60Hz (16:9)
Modeline..... "1920x1080" 148.500 1920 2008 2052 2200 1080 1084 1089 1125 +hsync +vsync
Detailed timing #2..... 1920x1080i at 60Hz (16:9)
Modeline..... "1920x1080i" 74.250 1920 2008 2052 2200 1080 1084 1094 1124 interlace +hsync
+vsync
Detailed timing #3..... 1280x720p at 60Hz (16:9)
Modeline..... "1280x720" 74.250 1280 1390 1430 1650 720 725 730 750 +hsync +vsync
Detailed timing #4..... 720x480p at 60Hz (16:9)
Modeline..... "720x480" 27.000 720 736 798 858 480 489 495 525 -hsync -vsync

CE video identifiers (VICs) - timing/formats supported
1920 x 1080p at 60Hz - HDTV (16:9, 1:1)
1920 x 1080i at 60Hz - HDTV (16:9, 1:1)
1280 x 720p at 60Hz - HDTV (16:9, 1:1) [Native]
720 x 480p at 60Hz - EDTV (16:9, 32:27)
720 x 480p at 60Hz - EDTV (4:3, 8:9)
720 x 480i at 60Hz - Doublescan (16:9, 32:27)
720 x 576i at 50Hz - Doublescan (16:9, 64:45)
640 x 480p at 60Hz - Default (4:3, 1:1)
NB: NTSC refresh rate = (Hz*1000)/1001

CE audio data (formats supported)
LPCM 2-channel, 16/20/24 bit depths at 32/44/48 kHz

CE vendor specific data (VSDB)
IEEE registration number. 0x000C03
CEC physical address..... 1.0.0.0
Maximum TMDS clock..... 165MHz

CE speaker allocation data
Channel configuration.... 2.0
Front left/right..... Yes
Front LFE..... No
Front center..... No
Rear left/right..... No
Rear center..... No
Front left/right center.. No
Rear left/right center... No
Rear LFE..... No

Report information
Date generated..... 11/11/2014
Software revision..... 2.60.0.972
Data source..... Real-time 0x0032
Operating system..... 6.1.7601.2.Service Pack 1

7 Technical Specifications

INPUT:	1 HDMI connector
OUTPUTS:	4 HDBT connectors
MAX. DATA RATE:	10.2Gbps (3.4Gbps per graphic channel)
MAX. RESOLUTION:	4K@30Hz and 4K@60Hz 4:2:0
COMPLIANCE WITH HDMI STANDARD:	Supports HDMI and HDCP
CONTROLS:	EDID Setup button
INDICATOR LEDs:	OUTPUTS 1 to 4, LINK 1 to 4, IN
OPERATING TEMPERATURE:	0° to +40°C (32° to 104°F)
STORAGE TEMPERATURE:	-40° to +70°C (-40° to 158°F)
HUMIDITY:	10% to 90%, RHL non-condensing
POWER CONSUMPTION:	5V DC, 3.2A
DIMENSIONS:	18.8cm x 11.5cm x 2.9cm (7.4" x 4.53" x 1.15") W, D, H
WEIGHT:	0.46kg (1.01lb)
ACCESSORIES:	Power supply
OPTIONS:	RK-T2B 19" rack adapter
Specifications are subject to change without notice at http://www.kramerelectronics.com	

7.1 Default Communication Parameters

RS-232	
Baud Rate:	115,200
Data Bits:	8
Stop Bits:	1
Parity:	None
Factory Reset	
Protocol 3000	FACTORY command to reset to factory default configuration
RS-232	
Command Format:	ASCII protocol 3000
Example (Route the video HDMI input to the output ports):	#ROUTE 1,1,2<cr>

8 Protocol 3000

The **VM-4HDT** can be operated using serial commands from a PC, remote controller, or touch screen. The unit communicates using the default Kramer Protocol 3000.

This section describes:

- Kramer Protocol 3000 syntax (see [Section 8.1](#))
- Kramer Protocol 3000 commands (see [Section 8.2](#))
- Kramer Protocol 3000 detailed commands (See [Section 8.3](#))

8.1 Kramer Protocol 3000 Syntax

8.1.1 Host Message Format

Start	Address (optional)	Body	Delimiter
#	<i>device_id@</i>	Message	CR

8.1.1.1 Simple Command

Command string with only one command without addressing:

Start	Body	Delimiter
#	Command SP <i>Parameter_1,Parameter_2,...</i>	CR

8.1.1.2 Command String

Formal syntax with commands concatenation and addressing:

Start	Address (optional)	Body	Delimiter
#	<i>device_id@</i>	Command_1 <i>Parameter1_1,Parameter1_2,...</i> Command_2 <i>Parameter2_1,Parameter2_2,...</i> Command_3 <i>Parameter3_1,Parameter3_2,... ...</i>	CR

8.1.2 Device Message Format

Start	Address (optional)	Body	Delimiter
#	<i>device_id@</i>	Message	CR LF

8.1.2.1 Device Long Response

Echoing command:

Start	Address (optional)	Body	Delimiter
~	device_id@	Command SP [Param1 ,Param2 ...] result	CR LF

CR = Carriage return (ASCII 13 = 0x0D)

LF = Line feed (ASCII 10 = 0x0A)

SP = Space (ASCII 32 = 0x20)

8.1.3 Command Terms

Command

A sequence of ASCII letters ('A'-'Z', 'a'-'z' and '-').

Command and parameters must be separated by at least one space.

Parameters

A sequence of alphanumeric ASCII characters ('0'-'9','A'-'Z','a'-'z' and some special characters for specific commands). Parameters are separated by commas.

Message string

Every command entered as part of a message string begins with a **message starting character** and ends with a **message closing character**.

Note: A string can contain more than one command. Commands are separated by a pipe ('|') character.

Message starting character

'#' – For host command/query

'~' – For device response

Device ID (Optional, for K-NET)

K-NET Device ID followed by '@'

Query sign

'?' follows some commands to define a query request.

Message closing character

CR – For host messages; carriage return (ASCII 13)

CRLF – For device messages; carriage return (ASCII 13) + line-feed (ASCII 10)

Command chain separator character

When a message string contains more than one command, a pipe ('|') character separates each command.

Spaces between parameters or command terms are ignored.

8.1.4 Entering Commands

You can directly enter all commands using a terminal with ASCII communications software, such as HyperTerminal, Hercules, etc. Connect the terminal to the serial or Ethernet port on the Kramer device. To enter **CR** press the Enter key. (**LF** is also sent but is ignored by command parser).

For commands sent from some non-Kramer controllers like Crestron, some characters require special coding (such as, /X##). Refer to the controller manual.

8.1.5 Command Forms

Some commands have short name syntax in addition to long name syntax to allow faster typing. The response is always in long syntax.

8.1.6 Chaining Commands

Multiple commands can be chained in the same string. Each command is delimited by a pipe character ("|"). When chaining commands, enter the **message starting character** and the **message closing character** only once, at the beginning of the string and at the end.

Commands in the string do not execute until the closing character is entered.

A separate response is sent for every command in the chain.

8.1.7 Maximum String Length

64 characters

8.2 Kramer Protocol 3000 Commands

Command	Description	Permission
#	Protocol handshaking	End User
BUILD-DATE?	Read device build date	End User
CPEDID	Copy EDID data from the output to the input EEPROM	End User
DISPLAY?	Read if output is valid	End User
FACTORY	Reset to factory default configuration	
GEDID	Read EDID data	User SW Internal
HELP	List of commands	End User
MODEL?	Read device model	End User
NAME?		
PROT-VER?	Read device protocol version	End User
RESET	Reset device	Administrator
SIGNAL?	Read if input is valid	End User
SN?	Read device serial number	End User



Note that the some of the following commands differ from the Kramer standard protocol commands.

8.3 Kramer Protocol 3000 – Detailed Commands

This section describes the detailed commands list.

Command - BUILD-DATE		Command Type - System-mandatory	
Command Name		Permission	Transparency
Set:	-	-	-
Get:	BUILD-DATE?	End User	Public
Description		Syntax	
Set:	Get device build date	# BUILD-DATE _{CR}	
Get:	-	-	
Response			
- _{nl} @ BUILD-DATE _{SP} <i>date</i> _{SP} <i>time</i> _{CR LF}			
Parameters			
<i>date</i> - Format: YYYY/MM/DD where YYYY = Year, MM = Month, DD = Day			
<i>time</i> - Format: hh:mm:ss where hh = hours, mm = minutes, ss = seconds			

Command - CPEDID		Command Type - System	
Command Name		Permission	Transparency
Set:	CPEDID	End User	Public
Get:	-	-	-
Description		Syntax	
Set:	Copy EDID data from the output to the input EEPROM	# CPEDID <input type="checkbox"/> <i>output_id</i> , <i>input_id</i> <input type="checkbox"/>	
Get:	-	-	
Response			
~ <input type="checkbox"/> <input type="checkbox"/> @ CPEDID <input type="checkbox"/> <i>output_id</i> , <i>input_id</i> <input type="checkbox"/> <input type="checkbox"/>			
Parameters			
<i>output_id</i> – Video output id <i>input_id</i> – Video input id			
Response Triggers			
Response is sent to the com port from which the Set was received (before execution)			

Command - DISPLAY?		Command Type - System	
Command Name		Permission	Transparency
Set:	-	-	-
Get	DISPLAY?	End User	Public
Description		Syntax	
Set:	-	-	
Get:	Get output HPD status	# DISPLAY? <input type="checkbox"/> <i>out_id</i> <input type="checkbox"/>	
Response			
~ <input type="checkbox"/> <input type="checkbox"/> @ DISPLAY <input type="checkbox"/> <i>out_id</i> , <i>status</i> <input type="checkbox"/> <input type="checkbox"/>			
Parameters			
<i>out_id</i> - output number <i>status</i> - HPD status according to signal validation – 0: Signal or sink is not valid, 1: Signal or sink is valid			
Response Triggers			
After execution, response is sent to the com port from which the Get was received Response is sent after every change in output HPD status ON to OFF Response is sent after every change in output HPD status OFF to ON and ALL parameters (new EDID, etc.) are stable and valid			

Command – FACTORY		Command Type – System-mandatory	
Command Name		Permission	Transparency
Set:	FACTORY	End User	-
Get:	-	-	-
Description		Syntax	
Set:	Reset device to factory defaults configuration	#FACTORY _{CR}	
Get :	-	-	
Response			
~nn@FACTORY _{SP} OK _{CR LF}			
Notes			
This command deletes all user data from the device. The deletion can take some time.			

Command - GEDID		Command Type - System	
Command Name		Permission	Transparency
Get:	GEDID	End User	Public
Description		Syntax	
Get:	Read EDID data	#GEDID _{SP} eeeprom_id _{CR}	
Response			
Multi line response:			
~nn@GEDID _{SP} eeeprom_id,size _{CR LF}			
EDID_data _{CR LF}			
~nn@GEDID _{SP} eeeprom_id _{SP} OK _{CR LF}			
Parameters			
<i>eeeprom_id</i> – EEPROM to get the EDID from			
<i>size</i> – Device sends this parameter in response. Size of EDID that will print.			
<i>edid_data</i> – EDID data as stream of bytes.			
Response Triggers			
Response is sent to the com port from which the Set (before execution) / Get command was received			
Notes			
For Get, size=0 means EDID is not supported			
For old devices that do not support this command, ~nn@ ERR 002 _{CR LF} is received			

Command - HELP		Command Type - System-mandatory	
Command Name		Permission	Transparency
Set:	-	-	-
Get:	HELP	End User	Public
Description		Syntax	
Set:	-	-	
Get:	Get command list or help for specific command	2 options: 1. #HELP ^{CR} 2. #HELP ^{SP} command_name ^{CR}	
Response			
1. Multi-line: ~nn@Device available protocol 3000 commands: ^{CR LF} command ^{SP} command... ^{CR LF} To get help for command use: HELP (COMMAND_NAME)^{CR LF} 2. Multi-line: ~nn@HELP ^{SP} command: ^{CR LF} description ^{CR LF} USAGE: usage ^{CR LF}			

Command - NAME		Command Type - System (Ethernet)	
Command Name		Permission	Transparency
Set:	NAME	Administrator	Public
Get:	NAME?	End User	Public
Description		Syntax	
Set:	Set machine (DNS) name	#NAME ^{SP} machine_name ^{CR}	
Get:	Get machine (DNS) name	#NAME? ^{CR}	
Response			
Set: ~nn@NAME ^{SP} machine_name ^{CR LF} Get: ~nn@NAME? ^{SP} machine_name ^{CR LF}			
Parameters			
machine_name - String of up to 15 alpha-numeric chars (can include hyphen, not at the beginning or end)			
Notes			
The machine name is not the same as the model name. The machine name is used to identify a specific machine or a network in use (with DNS feature on)			

Command - MODEL?		Command Type - System-mandatory	
Command Name		Permission	Transparency
Set:	-	-	-
Get:	MODEL?	End User	-
Description		Syntax	
Set:	-	-	
Get :	Get device model	#MODEL? ^{CR}	
Response			
~nn@MODEL ^{SP} model_name ^{CR LF}			
Parameters			
model_name - String of up to 19 printable ASCII chars			

Command - PROT-VER?		Command Type - System-mandatory	
Command Name		Permission	Transparency
Set:	-	-	-
Get:	PROT-VER?	End User	Public
Description		Syntax	
Set:	-	-	
Get:	Get device protocol version	# PROT-VER? <input type="checkbox"/> CR	
Response			
~ <input type="checkbox"/> nn@ PROT-VER? <input type="checkbox"/> SP3000:version <input type="checkbox"/> CR LF			
Parameters			
Version - XX.XX where X is a decimal digit			

Command - RESET		Command Type - System-mandatory	
Command Name		Permission	Transparency
Set:	RESET	Administrator	Public
Get:	-	-	-
Description		Syntax	
Set:	Reset device	# RESET <input type="checkbox"/> CR	
Get:	-	-	
Response			
~ <input type="checkbox"/> nn@ RESET <input type="checkbox"/> SPOK <input type="checkbox"/> CR LF			
Notes			
To avoid locking the port due to a USB bug in Windows, disconnect USB connections immediately after running this command. If the port was locked, disconnect and reconnect the cable to reopen the port.			

Command - SIGNAL		Command Type - System	
Command Name		Permission	Transparency
Set:	-	-	-
Get:	SIGNAL?	End User	Public
Description		Syntax	
Set:	-	-	
Get:	Get input signal lock status	# SIGNAL? <input type="checkbox"/> SPinp_id <input type="checkbox"/> CR	
Response			
~ <input type="checkbox"/> nn@ SIGNAL? <input type="checkbox"/> SPinp_id,status <input type="checkbox"/> CR LF			
Parameters			
inp_id - input number status - lock status according to signal validation – 0: Signal or sink is not valid, 1: Signal or sink is valid			
Response Triggers			
After execution, a response is sent to the com port from which the Get was received Response is sent after every change in input signal status ON to OFF, or OFF to ON			

Command - SN?		Command Type - System-mandatory	
Command Name		Permission	Transparency
Set:	-	-	-
Get:	SN?	End User	Public
Description		Syntax	
Set:	-	-	
Get:	Get device serial number	#SN? _{CR}	
Response			
~ _{hh} @SN _{SP} serial_number _{CR LF}			
Parameters			
serial_number - 11 decimal digits, factory assigned			
Notes			
For new products with 14 digit serial numbers, use only the last 11 digits			

8.3.1 Packet Protocol Structure

The packet protocol is designed to transfer large amounts of data, such as files, IR commands, EDID data, and so on.

8.3.1.1 Using the Packet Protocol

To use the packet protocol:

4. Send a command: LDEDID
5. Receive Ready or ERR###
6. If Ready:
 - Send a packet
 - Receive OK on the last packet
 - Receive OK for the command
7. Packet structure:
 - Packet ID (1, 2, 3...) (2 bytes in length)
 - Length (data length + 2 for CRC) - (2 bytes in length)
 - Data (data length - 2 bytes)
 - CRC - 2 bytes

01	02	03	04	05...	
Packet ID		Length		Data	CRC

8. Response:

~NNNN[SP]OK[CR][LF]

Where NNNN is the received packet ID in ASCII hex digits.

8.3.1.2 Calculating the CRC

The polynomial for the 16-bit CRC is:

CRC-CCITT: $0x1021 = x^{16} + x^{12} + x^5 + 1$

Initial value: 0000

Final XOR Value: 0

For a code example, see:

http://sanity-free.org/133/crc_16_ccitt_in_csharp.html

CRC example:

Data = "123456789"

Result => 0x31C3

LIMITED WARRANTY

The warranty obligations of Kramer Electronics for this product are limited to the terms set forth below:

What is Covered

This limited warranty covers defects in materials and workmanship in this product.

What is Not Covered

This limited warranty does not cover any damage, deterioration or malfunction resulting from any alteration, modification, improper or unreasonable use or maintenance, misuse, abuse, accident, neglect, exposure to excess moisture, fire, improper packing and shipping (such claims must be presented to the carrier), lightning, power surges, or other acts of nature. This limited warranty does not cover any damage, deterioration or malfunction resulting from the installation or removal of this product from any installation, any unauthorized tampering with this product, any repairs attempted by anyone unauthorized by Kramer Electronics to make such repairs, or any other cause which does not relate directly to a defect in materials and/or workmanship of this product. This limited warranty does not cover cartons, equipment enclosures, cables or accessories used in conjunction with this product.

Without limiting any other exclusion herein, Kramer Electronics does not warrant that the product covered hereby, including, without limitation, the technology and/or integrated circuit(s) included in the product, will not become obsolete or that such items are or will remain compatible with any other product or technology with which the product may be used.

How Long Does this Coverage Last

Seven years as of this printing; please check our Web site for the most current and accurate warranty information.

Who is Covered

Only the original purchaser of this product is covered under this limited warranty. This limited warranty is not transferable to subsequent purchasers or owners of this product.

What Kramer Electronics will do

Kramer Electronics will, at its sole option, provide one of the following three remedies to whatever extent it shall deem necessary to satisfy a proper claim under this limited warranty:

1. Elect to repair or facilitate the repair of any defective parts within a reasonable period of time, free of any charge for the necessary parts and labor to complete the repair and restore this product to its proper operating condition. Kramer Electronics will also pay the shipping costs necessary to return this product once the repair is complete.
2. Replace this product with a direct replacement or with a similar product deemed by Kramer Electronics to perform substantially the same function as the original product.
3. Issue a refund of the original purchase price less depreciation to be determined based on the age of the product at the time remedy is sought under this limited warranty.

What Kramer Electronics will not do Under This Limited Warranty

If this product is returned to Kramer Electronics or the authorized dealer from which it was purchased or any other party authorized to repair Kramer Electronics products, this product must be insured during shipment, with the insurance and shipping charges prepaid by you. If this product is returned uninsured, you assume all risks of loss or damage during shipment. Kramer Electronics will not be responsible for any costs related to the removal or re-installation of this product from or into any installation. Kramer Electronics will not be responsible for any costs related to any setting up this product, any adjustment of user controls or any programming required for a specific installation of this product.

How to Obtain a Remedy under this Limited Warranty

To obtain a remedy under this limited warranty, you must contact either the authorized Kramer Electronics reseller from whom you purchased this product or the Kramer Electronics office nearest you. For a list of authorized Kramer Electronics resellers and/or Kramer Electronics authorized service providers, please visit our web site at www.kramerelectronics.com or contact the Kramer Electronics office nearest you.

In order to pursue any remedy under this limited warranty, you must possess an original, dated receipt as proof of purchase from an authorized Kramer Electronics reseller. If this product is returned under this limited warranty, a return authorization number, obtained from Kramer Electronics, will be required. You may also be directed to an authorized reseller or a person authorized by Kramer Electronics to repair the product.

If it is decided that this product should be returned directly to Kramer Electronics, this product should be properly packed, preferably in the original carton, for shipping. Cartons not bearing a return authorization number will be refused.

Limitation on Liability

THE MAXIMUM LIABILITY OF KRAMER ELECTRONICS UNDER THIS LIMITED WARRANTY SHALL NOT EXCEED THE ACTUAL PURCHASE PRICE PAID FOR THE PRODUCT. TO THE MAXIMUM EXTENT PERMITTED BY LAW, KRAMER ELECTRONICS IS NOT RESPONSIBLE FOR DIRECT, SPECIAL, INCIDENTAL OR CONSEQUENTIAL DAMAGES RESULTING FROM ANY BREACH OF WARRANTY OR CONDITION, OR UNDER ANY OTHER LEGAL THEORY. Some countries, districts or states do not allow the exclusion or limitation of relief, special, incidental, consequential or indirect damages, or the limitation of liability to specified amounts, so the above limitations or exclusions may not apply to you.

Exclusive Remedy

TO THE MAXIMUM EXTENT PERMITTED BY LAW, THIS LIMITED WARRANTY AND THE REMEDIES SET FORTH ABOVE ARE EXCLUSIVE AND IN LIEU OF ALL OTHER WARRANTIES, REMEDIES AND CONDITIONS, WHETHER ORAL OR WRITTEN, EXPRESS OR IMPLIED. TO THE MAXIMUM EXTENT PERMITTED BY LAW, KRAMER ELECTRONICS SPECIFICALLY DISCLAIMS ANY AND ALL IMPLIED WARRANTIES, INCLUDING, WITHOUT LIMITATION, WARRANTIES OF MERCHANTABILITY AND FITNESS FOR A PARTICULAR PURPOSE. IF KRAMER ELECTRONICS CANNOT LAWFULLY DISCLAIM OR EXCLUDE IMPLIED WARRANTIES UNDER APPLICABLE LAW, THEN ALL IMPLIED WARRANTIES COVERING THIS PRODUCT, INCLUDING WARRANTIES OF MERCHANTABILITY AND FITNESS FOR A PARTICULAR PURPOSE, SHALL APPLY TO THIS PRODUCT AS PROVIDED UNDER APPLICABLE LAW.

IF ANY PRODUCT TO WHICH THIS LIMITED WARRANTY APPLIES IS A "CONSUMER PRODUCT" UNDER THE MAGNUSON-MOSS WARRANTY ACT (15 U.S.C.A. §2301, ET SEQ.) OR OTHER APPLICABLE LAW, THE FOREGOING DISCLAIMER OF IMPLIED WARRANTIES SHALL NOT APPLY TO YOU, AND ALL IMPLIED WARRANTIES ON THIS PRODUCT, INCLUDING WARRANTIES OF MERCHANTABILITY AND FITNESS FOR THE PARTICULAR PURPOSE, SHALL APPLY AS PROVIDED UNDER APPLICABLE LAW.

Other Conditions

This limited warranty gives you specific legal rights, and you may have other rights which vary from country to country or state to state.

This limited warranty is void if (i) the label bearing the serial number of this product has been removed or defaced, (ii) the product is not distributed by Kramer Electronics or (iii) this product is not purchased from an authorized Kramer Electronics reseller. If you are unsure whether a reseller is an authorized Kramer Electronics reseller, please visit our Web site at www.kramerelectronics.com or contact a Kramer Electronics office from the list at the end of this document.

Your rights under this limited warranty are not diminished if you do not complete and return the product registration form or complete and submit the online product registration form. Kramer Electronics thanks you for purchasing a Kramer Electronics product. We hope it will give you years of satisfaction.

KRAMER



P/N:



2900-300486

Rev: 1



SAFETY WARNING

Disconnect the unit from the power supply before opening and servicing

For the latest information on our products and a list of Kramer distributors, visit our Web site where updates to this user manual may be found.

We welcome your questions, comments, and feedback.

www.kramerAV.com
info@kramerele.com